

Unit-I

1.0 Introduction to Mechatronics

The term "mechatronics" was first assigned by Mr. Tetsuro Mori, a senior engineer of the Japanese company Yaskawa, in 1969. Mechatronics basically refers to mechanicalelectronic systems

A synergistic combination of mechanical, electrical, electronics, computer and control systems which, when combined, make possible the generation of simple, more economic, and reliable systems.

Following figure 1.1 shows definition and applications area of mechatronics

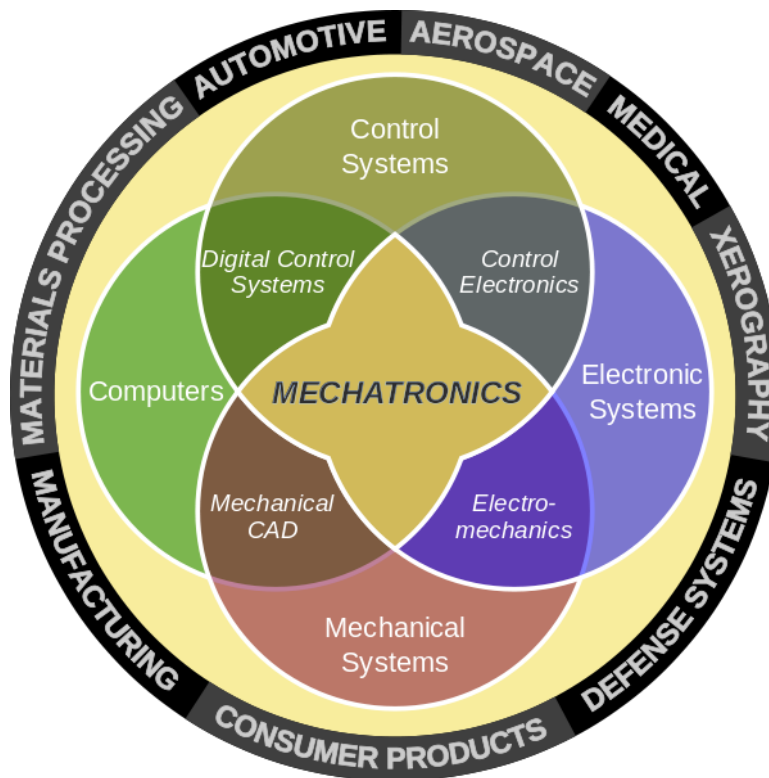

Figure 1.1 Applications of mechatronics

1.1 Key Elements of Mechatronics

Physically mechatronic system composed of four prime components

- Sensors,
- Actuators,
- Controllers and

- Mechanical/electrical components

Figure 1.2 shows Key elements of mechatronics system

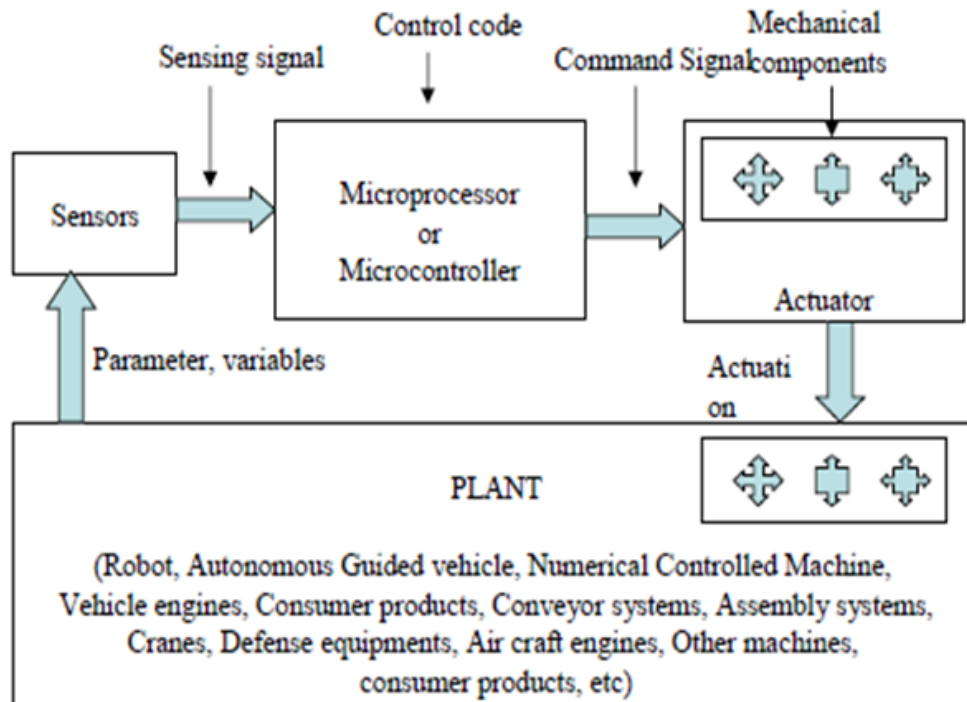

Figure 1.2 Key elements of mechatronics system

1.1.1 Sensors

A sensor is a device that measures a physical quantity and converts it into an 'electrical signal' which can be read by an observer or by an instrument.

- Temperature sensors
- Displacement, position, motion and velocity sensors,
- Fluid sensors, liquid flow, liquid level
- Light sensors etc.,

1.1.2 Actuator

Actuator is transducer which converts electrical signal into physical quantity

- An actuator is a component of a machine that is responsible for moving or controlling a mechanism or system.
- Mechanical Actuation systems
 - Gear trains Belt
 - and chain drives, bearings etc.,

- Electrical Actuation systems
 - Mechanical switches - Keyboards, limit switches, switches, Relays
 - Solid-state switches - Diodes, thyristors, transistors
 - Solenoids– Push something, Starter solenoid, pneumatic or hydraulic valve
 - Drive systems - DC, AC, or stepper motors

1.1.3 Microcontroller

Integrated electronic computing device that includes three major components on a single chip

- Microprocessor (MPU)
- Memory
- I/O (Input/Output) ports

Figure 1.3 shows Basic blocks of Microcontroller

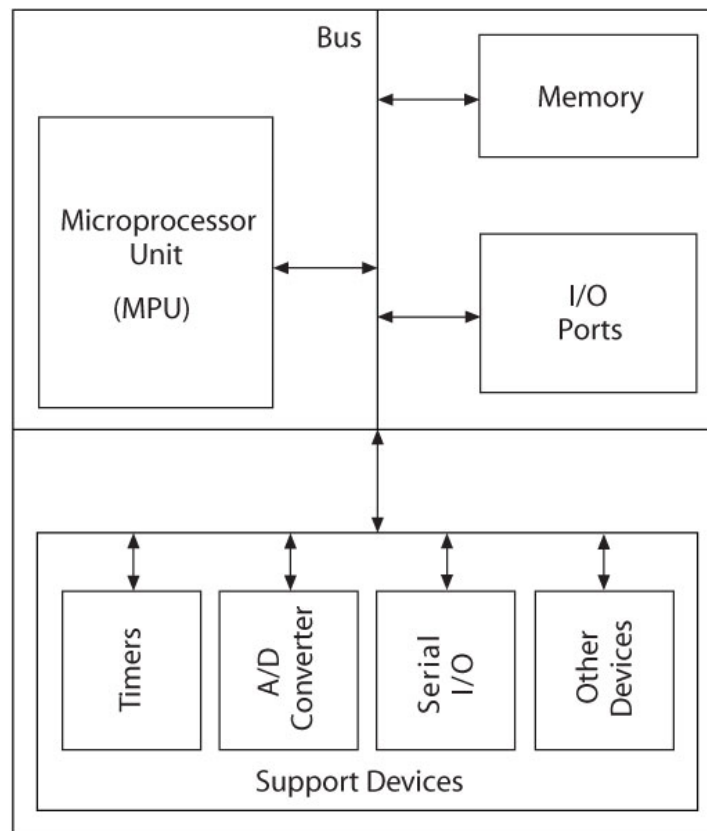

Figure 1.3 Basic blocks of Microcontroller

Microprocessor: Integrated electronic computing device that includes Arithmetic Logic Unit (ALU), Control Unit and Register array or Simply CPU on a single IC. It takes digital data as input, process the data and gives digital data as output.

Input Devices: Provide binary information to the MPU

- Switches and Keypads

Output devices: Receive binary information from the MPU

- LEDs and LCDs

Memory:Storage Device

Major Categories

- Read/Write Memory (R/W)
- Read-only-Memory (ROM)

1.2 Difference between Microprocessor and Microcontrollers

Microprocessor

- CPU is stand-alone, RAM, ROM, I/O, timer are separate
- designer can decide on the amount of ROM, RAM and I/O ports.
- expensive
- general-purpose
- High processing power
- High power consumption
- Instruction sets focus on processing-intensive operations
- Typically 32/64 – bit
- Typically deep pipeline (5-20 stages)

Microcontroller

- CPU, RAM, ROM, I/O and timer are all on a single chip
- fixed amount of on-chip ROM, RAM, I/O ports
- for applications in which cost, power and space are critical
- single-purpose (control-oriented)
- Low processing power
- Low power consumption
- Bit-level operations
- Instruction sets focus on control and bit-level operations
- Typically 8/16 bit
- Typically single-cycle/two-stage pipeline

1.3 Arduino

Arduino is an open-source electronics platform which integrates hardware and software easily. Arduino boards are able to read inputs - light on a sensor, a finger on a button, or a Twitter message - and turn it into an output - activating a motor, turning on an LED, publishing something online. You can tell your board what to do by sending a set of instructions to the microcontroller on the board.

1.3.1 Arduino Boards

- Arduino Uno
- Arduino NG, Diecimila, and the Duemilanove (Legacy Versions)
- Arduino Mega 2560
- Arduino Mega ADK

- ArduinoLilyPad

1.3.2 Arduino Pin map

The figure 1.4 shows Arduino Mega Pin map

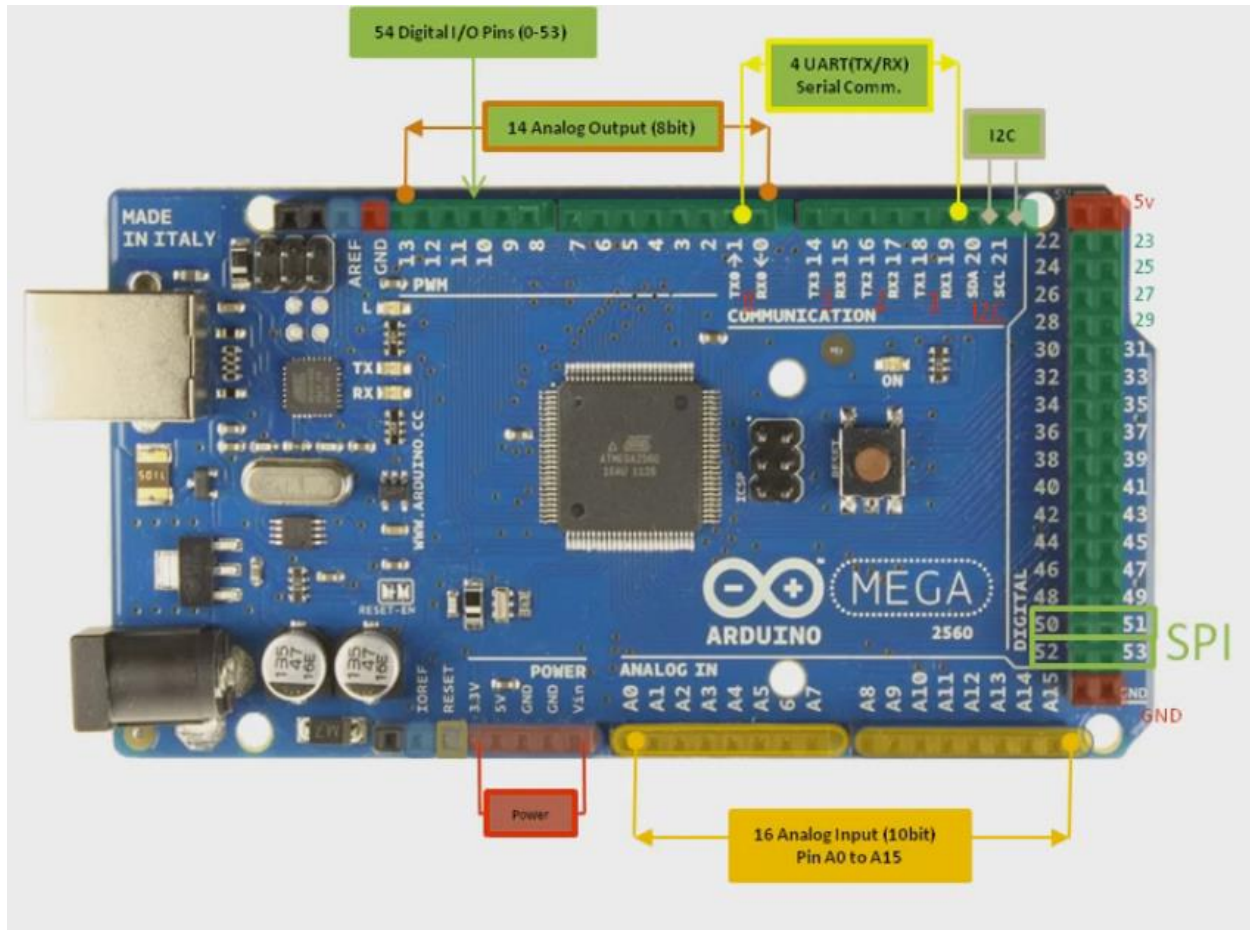

Figure 1.4 shows Arduino Mega Pin map

ATmega2560:

- The Arduino Mega 2560 is a microcontroller board based on the ATmega2560.
- The ATmega640/1280/1281/2560/2561 is a low-power CMOS 8-bit microcontroller based on the AVR enhanced RISC architecture.
- It has 54 digital input/output pins (of which 14 can be used as PWM outputs), 16 analog inputs, 4 UARTs (hardware serial ports), a 16 MHz crystal oscillator, a USB connection, a power jack, an ICSP header, and a reset button.
- It contains everything needed to support the microcontroller;
- Simply connect it to a computer with a USB cable or power it with a AC-to-DC adapter or battery to get started.

- Memory - The ATmega2560 has 256 KB of flash memory for storing code (of which 8 KB is used for the bootloader), 8 KB of SRAM and 4 KB of EEPROM (which can be read and written with the EEPROM library).

Power pins:

- **V_{IN}**: Used to turn ON the board using battery.
- **5V**. It is used to power external components connected to Arduino which needs 5V.
- **3V3**. It is used to power external components connected to Arduino which needs 3.3V. Maximum current draw is 50 mA.
- **GND**. Ground

Digital Input/Output(I/O):

Each of the 54 digital pins on the Mega can be used as an input or output, using `pinMode()`, `digitalWrite()`, and `digitalRead()` functions. They operate at 5 volts. Each pin can provide or receive a maximum of 40 mA and has an internal pull-up resistor (disconnected by default) of 20-50 k Ω . In addition, some pins have specialized functions

Universal Asynchronous Receiver and Transmitter (UART): Used to receive (RX) serial data and transmit (TX) serial data.

- UART 0: 0 (RX) and 1 (TX)
- UART 1: 19 (RX) and 18 (TX)
- UART 2: 17 (RX) and 16 (TX)
- UART 3: 15 (RX) and 14 (TX).

Pulse Width Modulation (PWM): 0 to 13. Provide 8-bit PWM output with the `analogWrite()` function. These pins are also called as analog output lines

Serial Peripheral Interface(SPI): 50 (MISO), 51 (MOSI), 52 (SCK), 53 (SS).

- MISO (Master In Slave Out)
- MOSI (Master Out Slave In)
- SCK (Serial Clock)
- SS (Serial Select)

LED: 13. There is a built-in LED connected to digital pin 13. When the pin is HIGH value, the LED is on, when the pin is LOW, it's off.

Inter integrated circuit (I2C): 20 (SDA) and 21 (SCL).

- **SDA** : Serial Data, It is the bidirectional data line that is used by I2C.

- **SCL** : Serial Clock, It is used to indicate that data is ready on bidirectional data line that is used by I2C.

Analog Inputs: The Arduino Mega2560 has 16 analog inputs, each of which provide 10 bits of resolution (i.e. 1024 different values).

There are a couple of other pins on the board.

AREF. Reference voltage for the analog inputs. Used with `analogReference()`.

Reset. It Resets the Arduino board if pressed

1.4 Arduino Programming

Structure: A basic Arduinosketch(Program) consists of two *functions* called `setup()` and `loop()`.

Where `setup()` is the preparation, `loop()` is the execution. Both functions are required for program to work. The `setup()` should follow the declaration of any variables at every beginning of the program. It is the first function to run in the program, is only run once, and used to set pinMode or initialize serial communication

The `loop()` follows next and includes the code to be executed continuously- reading inputs , triggering outputs etc., this function is core of all arduino programs does bulk of work.

The `setup()` Function

The `setup()` called once when program starts. Use it to initialize pin modes, or begin serial communication. It must be included in program even if there are no statements run.

The `loop()` Function

After calling the `setup()` function, the `loop()` function does precisely what its name suggests, and loops consecutively, allowing the program to change, respond and control the arduino board.

Example 1.1

```
// File: blink.pde
// Turns on an LED on for one second,
// then off for one second, repeatedly. Header: • Overview comments • Global variables
intLED_pin = 11;
void setup()           //• Execute only once • Tasks for start-up
{
    pinMode(LED_pin, OUTPUT);
```

```

    }
void loop()                                //• Execute repeatedly • Primary tasks for the sketch
{
    digitalWrite(LED_pin, HIGH);
    delay(1000);
    digitalWrite(LED_pin, LOW);
    delay(1000);
}

```

1.5 Arduino Basic functions

1.5.1 Digital I/O: Arduino mega 2560 have 54 digital I/O pins(0-53)

pinMode(pin, mode): Configures the specified pin to behave either as an input or an output.
pin is the pin number(0 - 53). Mode specifies INPUT/OUTPUT.

Ex: pinMode(7, OUTPUT); // sets the “pin 7” as output
 pinMode(1, INPUT); // sets the “pin 1” as input

digitalWrite(pin, value): Write a HIGH or a LOW value to a digital pin.

Ex: digitalWrite(14, HIGH); // write logic 1(5V) on to “pin 14”
 digitalWrite(52, LOW); // write logic 0(0V) on to “pin 52”

digitalRead(pin): Reads the value from a specified digital pin(0-53). The result will be either HIGH or LOW

Ex: value= digitalRead(10); // reads logic level(0/1) on pin 10 and assigns to value

1.5.2 Analog I/O: Arduino mega 2560 have 16analog I/O pins(0- 15)

analogRead(pin): Reads the value from the specified analog pin with a 10-bit resolution. This function works on analog input pins(0 - 15). The resulting integer values from 0 to 1023 to represent 0 to 5V. It takes about 0.0001 seconds to read an analog pin.

Ex: value=analogRead(0); // reads analog pin 0, converts 10-bit digital number assigns to value//

Note: Analog pins unlike digital ones do not need to declare as INPUT/OUTPUT.

analogWrite(pin,value):Arduino mega 2560 have 14PWMs (0- 13)

Writes analog value using hardware enabled pulse width modulation (PWM) to an output marked PWM. The value can be specified as a variable or constant with a value from 0-255.

Ex: `analogWrite(0,value); // write value to "PWM0"`

A value of 0 generates a steady state 0V output at the specified pin; a value of 255 generates 5V output at the specified pin. For values in between 0 and 255 the pin rapidly alternate between 0 and 5V. As value increases duty cycle of the pulse is increased.

analogReference(type): The default reference voltage is 5V. This can be changed to a different type and different resolution using this function.

1.5.3 Serial I/O: Typically used for communication between an Arduino board and a computer via the USB port. Use the serial monitor to communicate with the board.

Serial.begin(9600): Used to begin serial communications, typically at a 9600 baud rate (bits per second)

Serial.print(val,format): Prints data to the serial port as human-readable ASCII text.

Examples: `Serial.print(78)` gives "78"

`Serial.print(1.23456)` gives "1.23"

`Serial.println(1.23456, 4)` gives "1.2346"

`Serial.print("Hello world.")` gives "Hello world."

Serial.println(val): Prints val followed by carriage return

delay(): Pauses the program for the amount of time (in milliseconds) specified as parameter.

Syntax: `delay(ms)`

Parameters:

ms: The number of milliseconds to pause

Returns: Nothing

delayMicroseconds(): Pauses the program for the amount of time (in microseconds) specified as parameter.

Syntax: `delayMicroseconds(μ s)`

Parameters:

μ s: The number of microseconds to pause

Returns: Nothing

UNIT -II

SENSORS

2.0 Sensors: A sensor is a device that measures a physical quantity and converts it into a electrical signal. Examples of sensors are Temperature sensors, Displacement, position, motion and velocity sensors, Fluid sensors, liquid flow, liquid level, Light sensors etc.,

2.1 Characteristics of Sensors: Sensor characteristics are of two types

- Static Characteristics
- Dynamic Characteristics

Static characteristics refer to the steady state relationship between sensor input and output
Dynamic characteristics refer to the relationship between the sensor input and output when the measured quantity is varying rapidly.

2.1.1 Static Characteristics

- i) **Range:** The range of a sensor indicates the limits between which the input can vary.
Example: a thermocouple for the measurement of temperature might have a range of 25-225 °C.
- ii) **Span:** Span is difference between the maximum and minimum values of the input.
Thus, the above-mentioned thermocouple will have a span of $225-25=200$ °C.
- iii) **Error:** Error is the difference between the measured value and the true value of the quantity. Example: A sensor might give a displacement reading of 29.8 mm, when the actual displacement had been 30 mm, then the error is 0.2 mm.
- iv) **Sensitivity:** Sensitivity of a sensor is defined as the ratio of change in output value of a sensor per unit change in input value. For example, a temperature sensor may have a sensitivity of 10 mV/°C. If 1°C raise in temp results in 10mV.
- v) **Non-Linearity:** The nonlinearity indicates the maximum deviation of the actual measured curve of a sensor from the ideal curve. It is shown in fig. 2.1
- vi) **Hysteresis:** The hysteresis is an error of a sensor, which is defined as the maximum difference in output at any measurement value within the sensor's specified range when approaching the point first with increasing and then with decreasing the input parameter. It is shown in fig. 2.2

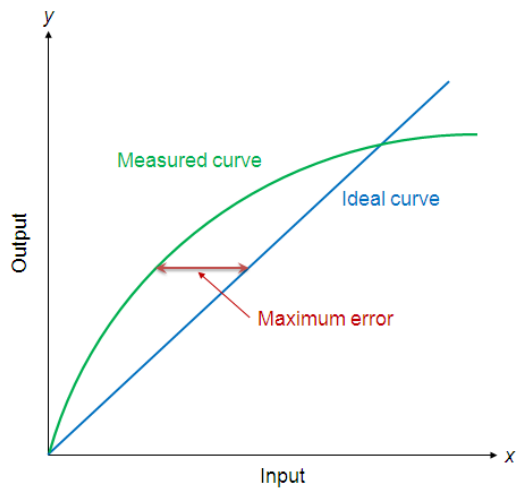

Fig. 2.1 Non-Linearity

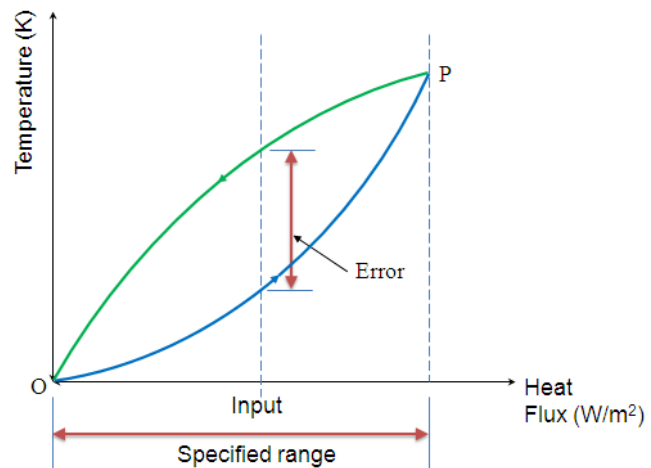

Fig. 2.2 Hysteresis

- vii) **Stability:** Stability is the ability of a sensor device to give same output with a constant input over a period.
- viii) **Dead band:** The dead band or dead space of a sensor is the range of input values for which there is no output.
- ix) **Repeatability:** It specifies the ability of a sensor to give same output for repeated applications of same input value under same conditions.
- x) **Accuracy:** This is the closeness to the actual value.
- xi) **Precision:** Precision is defined as the ability of sensor to reproduce a certain set of readings within given accuracy. Precision depends upon repeatability.
- xii) **Output Impedance:** It is the impedance measured at the output of sensor. It is necessary to know the output impedance of a sensor because the electrical output of sensor is interfaced with an electronic circuit.

2.1.2 Dynamic Characteristics

- i) **Response time:** This is the time which elapsed by sensor to gives an output corresponding to some specified percentage (90-95%) of its steady value after a constant input, a step input, is applied.
- ii) **Time constant:** The time constant is a measure of the inertia of the sensor and so how it will react to changes in its input. This is the 63.2% response time.
- iii) **Rise time:** This is the time taken for the output to rise from 10% to 90 % of its steady value.
- iv) **Settling time:** This is the time taken for the output to settle to within some small percentage (2%) of steady state value.

The Dynamic Characteristics are shown in Fig. 2.3

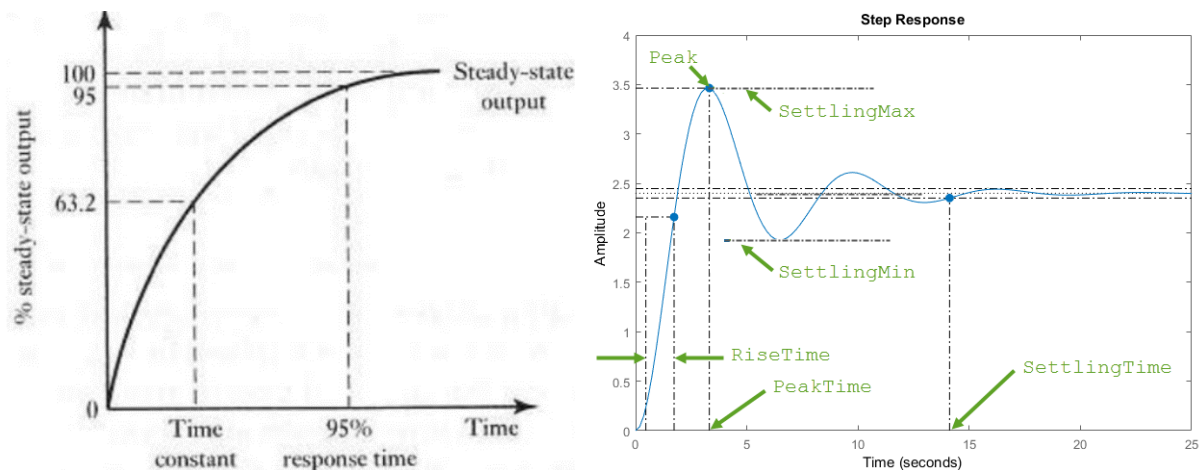

Fig. 2.3 Dynamic Characteristics of Sensors

2.2 Classification of sensors

In the first classification of the sensors, they are divided into Active and Passive.

Active sensors (self-generating): Does not require power for its operation. Ex: Thermocouple

Passive Sensors (external supply): Require external power for its operation Ex: Photodiode

In the second classification of the sensors, they are divided into Analog and digital.

Analog Sensors: Analog Sensors produce an analog output i.e. a continuous output signal with respect to the quantity being measured. Ex: LDR, Strain gauge

Digital Sensors: Digital Sensors, in contrast to Analog Sensors, work with discrete or digital data. The data in digital sensors, which is used for conversion and transmission, is digital in nature. Ex: IR, PIR

In the third classification of the sensors, they are divided into primary and secondary.

Primary Sensor: Primary transducers contain the mechanical as well as electrical device. It usually converts the physical quantity to be measured into a mechanical signal.

Secondary Sensor: Secondary transducers are deployed in cascade with primary one. This converts that mechanical signal into a more comprehensible electrical signal.

Ex: Bourdon tube (Primary sensor) and LVDT(Secondary sensor).

2.3 Selection of Sensors

The following parameters need to be considered while selecting a sensor for an application

- Operating principle

- Availability
 - Sources-Location, delivery schedule,
 - payment options, Continuation of supply.
- Cost: Cost of sensor itself, delivery cost.
- Performance figures:
 - Range, ease of use, power supply requirements, accuracy, hysteresis effect and any other

2.4 Displacement Sensors:

Displacement sensors are basically used for the measurement of movement of an object. The displacement sensor converts displacement into electrical signal. This electrical signal may Resistance/Capacitance/Inductance. Based on the electrical output, the displacement sensor classified into three types:

- Resistive Displacement sensors: Potentiometer, strain gauge
- Capacitive Displacement sensors: Capacitive element
- Inductive Displacement sensors: LVDT

2.4.1 Resistive Displacement sensors

i) Potentiometer:

Construction: It consist of a resistance element with sliding contact which can be moved over the length of the element as shown in fig. 2.4. The resistive element is a wire wound track or conductive plastic. Wire wound track has a resolution of the order of 0.5mm. The conductive plastic may have the resolution of about 0.1 μm .

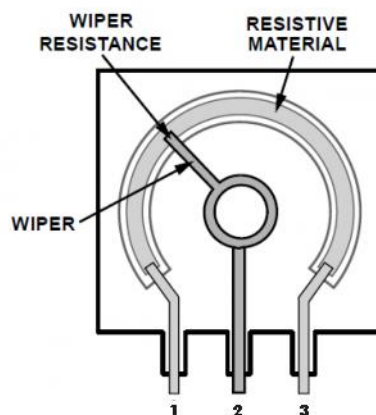

Fig. 2.4 Potentiometer Construction

Operation: Potentiometer is one of the common sensors for position measurements. It relates the change in position (linear or rotary) into the change in resistance, as shown in Figure 2.5 a and b. The resistance change is then converted to a proportional voltage change in the electrical circuit of the sensor. Hence, the relationship between the measured physical variable, translational(linear) displacement x or rotary(angular) displacement θ , and the output voltage for a ideal potentiometer is

$$V_{out} = kV_s x$$

$$V_{out} = kV_s \theta$$

Where V_s = supply voltage

X = linear displacement

θ = angular displacement.

V_{out} = output voltage

K = Sensitivity of the potentiometer is a function of the winding resistance and physical shape of the winding.

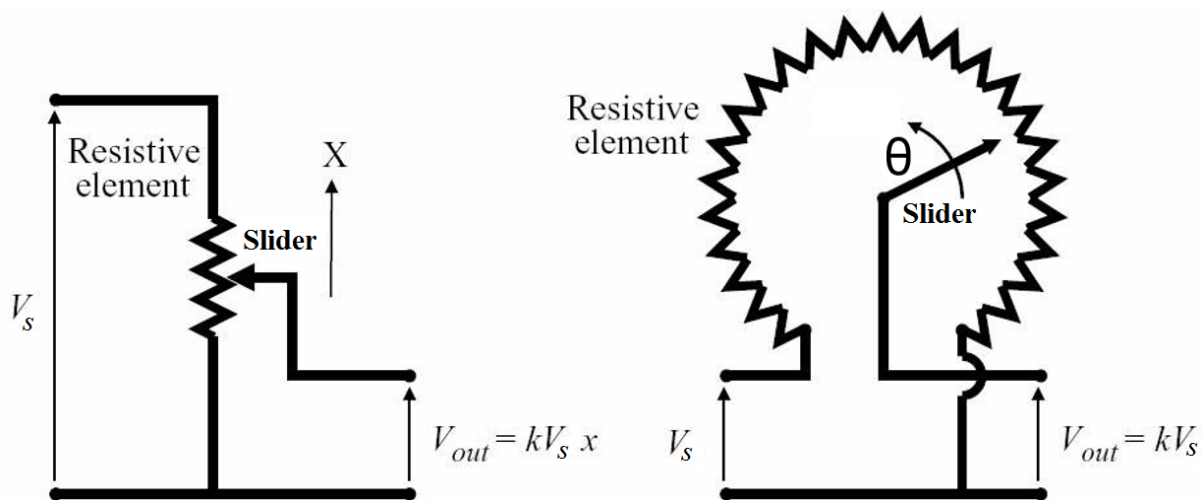

Fig. 2.5 (a) Linear displacement

Fig. 2.5 (b) Angular displacement

ii) **Strain gauge:** A strain gauge is an example of passive transducer that converts a mechanical displacement into a change of resistance. Strain gage is one of the most popular types of transducer. It has got a wide range of applications. It can be used for measurement of force, torque, pressure, acceleration and many other parameters. The basic principle of operation of a strain gage is simple: when strain is applied to a thin metallic wire, its dimension changes, thus changing the resistance of the wire. Let us first investigate what are the factors, responsible for the change in resistance.

Based on principle of working:

a. Mechanical

- b. Electrical
- c. Piezoelectric

Based on mounting:

- a. Bonded strain gauge
- b. Unbonded strain gauge

Out of these the most commonly used one is the electrical strain Gauge

Construction of electrical strain Gauge: There are many types of strain gauges. Among them, a universal strain gauge has a structure such that a grid-shaped sensing element of thin metallic resistive foil (3 to 6µm thick) is put on a base of thin plastic film (15 to 16µm thick) and is laminated with a thin film and is shown in fig. 2.6

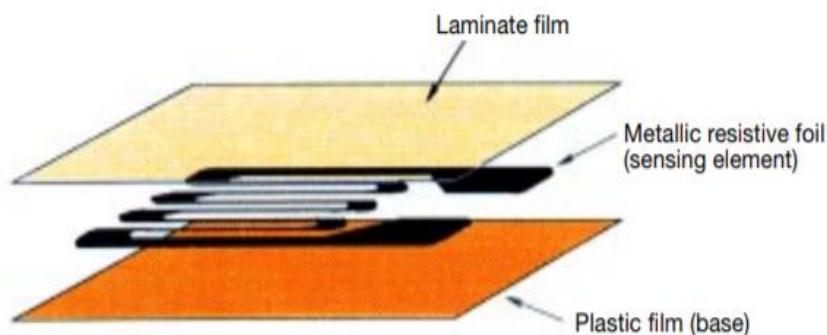

Fig. 2.6 Construction of Metal foil Strain gauge

Types of electrical strain Gauges: Types of electrical strain Gauges are shown in fig.2.7

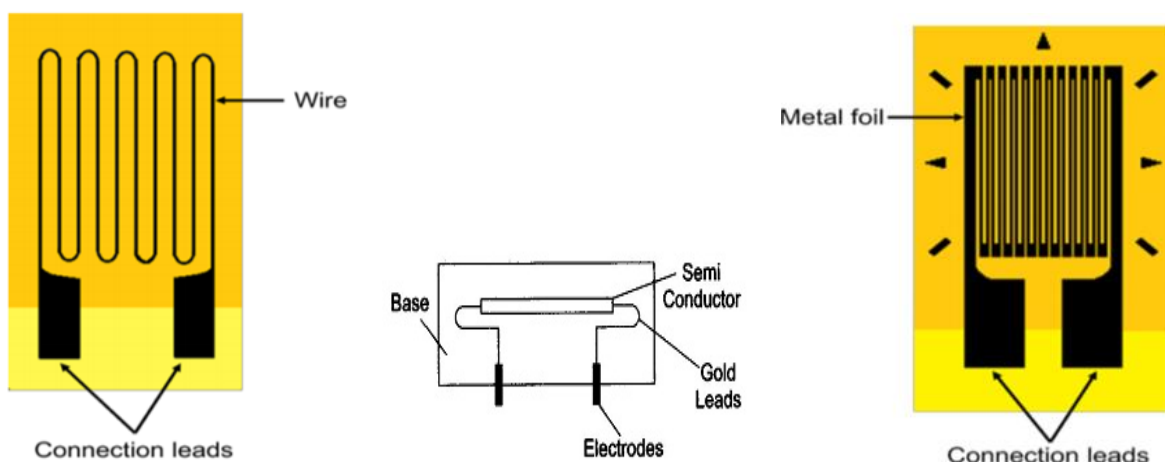

Fig.2.7 (a) Metal wire type (b) Semiconductor type (c) Metal foil type

Operation: The strain gauge is tightly bonded to a measuring object so that the sensing element (metallic foil) may stretch or contract according to the strain on the measuring object. The stretching and contraction may result in change length of the strain gauge as shown in fig. 2.8.

The change in length results change in resistance according to following equation

$$R = \frac{\rho l}{A}$$

Where R = Resistance

l= length

A= Area

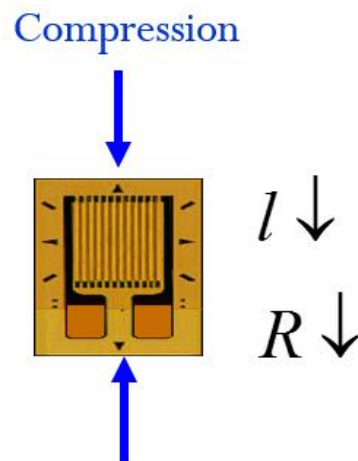
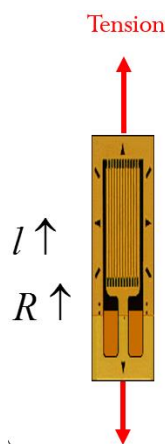

Fig. 2.8 Strain gauge under tension Fig. 2.7 Strain gauge under contraction

Hence the applied strain is directly proportional to the change in resistance

$$\frac{\Delta R}{R} = G \epsilon$$

where,

R=Original resistance of strain gage, Ω (ohm)

ΔR = Elongation- or contraction-initiated resistance change, Ω (ohm)

G= Proportional constant (called gage factor)

ϵ = Strain ($\frac{\Delta l}{l}$)

G= 2 for metal wire or metal foil strain gauge

G= -100 or less for N-type semiconductor

G= +100 or more for P-type semiconductor

Applications of Strain gauge:

- Displacement measurement
- Force measurement
- Residual stress
- Vibration measurement
- Torque measurement
- Bending and deflection measurement
- Compression and tension measurement

➤ Strain measurement

Displacement Measurement using Strain gauge: One form of displacement sensor has strain gauge attached to flexible element in the form of cantilevers, rings and U- shapes.

Fig.2.9 Shows displacement measurement using cantilever.



Fig. 2.9(a) Cantilever under no displacement

Fig. 2.9(b) Cantilever with displacement

When strain or force is applied on beam of cantilever, it is displaced, then the strain gauges mounted on the cantilever are also strained. which results in one strain gauge is under tension and one is under compression as shown in fig. 2.8(b) and give a resistance change which can be monitored. The change in resistance is thus measure of displacement of beam of cantilever. Such arrangements typically used for linear displacements of the order of 1mm to 30mm and Have non-linearity error of about $\pm 1\%$ of full range.

2.4.2 Inductive Displacement sensor: The best example of inductive displacement sensor is the Linear Variable Differential Transducer/Transformer (LVDT).

Linear Variable Differential Transducer/Transformer (LVDT):

Principle of LVDT: LVDT works under the principle of mutual induction, and the displacement which is a non-electrical energy is converted into an electrical energy.

Construction of LVDT: LVDT consists of a cylindrical former where it is surrounded by one primary winding in the centre of the former and the two secondary windings at the sides. The number of turns in both the secondary windings are equal, but they are opposite to each other, i.e., if the left secondary windings is in the clockwise direction, the right secondary windings will be in the anti-clockwise direction, hence the net output voltages will be the difference in voltages between the two-secondary coil. The two secondary coil is represented as S1 and S2. Esteem iron core is placed in the centre of the cylindrical former which can move in to and fro motion as shown in the figure 2.10. The AC excitation voltage is 5 to 12V and the operating frequency is given by 50 to 400 HZ.

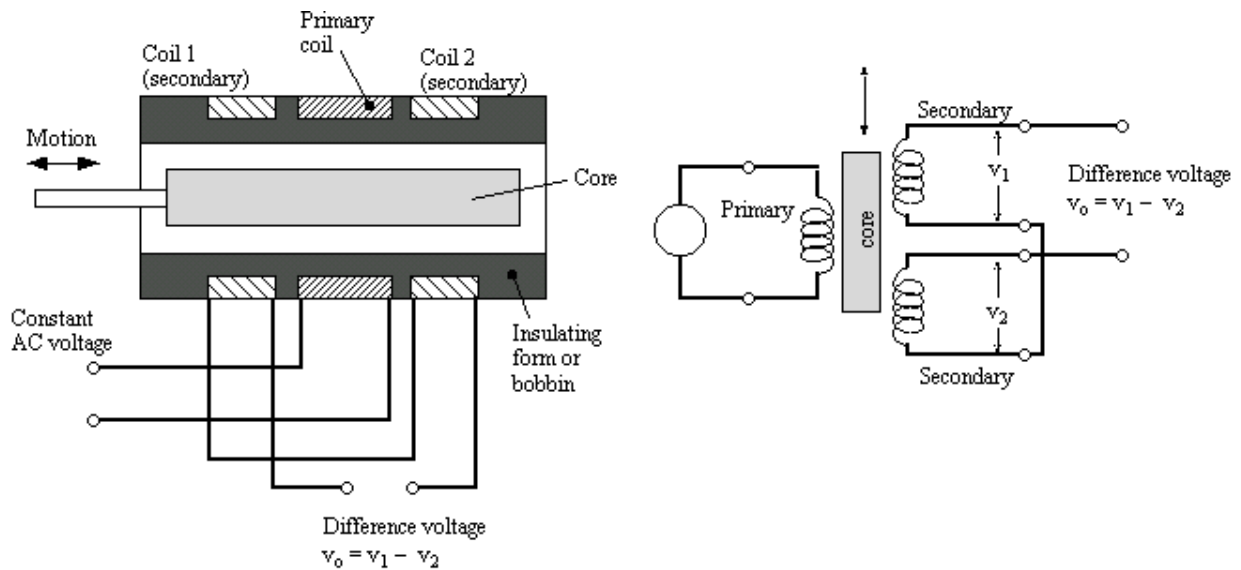

Fig. 2.10 (a) LVDT Construction Fig. 2.10 (b) LVDT Equivalent circuit

Working of LVDT:

The working of LVDT by splitting the cases into 3 based on the iron core position inside the insulated former.

Case 1: When no external force, the core remains in the null position itself without providing any movement then the voltage induced in both the secondary windings are equal which results in net output is equal to zero

$$V_0 = V_1 - V_2 = 0$$

Case 2: When an external force is applied and if the steel iron core tends to move in the left-hand side direction then the emf voltage induced in the secondary coil 1 is greater when compared to the emf induced in the secondary coil 2. Therefore, the net output will be

$$V_0 = V_1 - V_2 = +ve$$

Case 3: When an external force is applied and if the steel iron core moves in the right-hand side direction then the emf induced in the secondary coil 2 is greater when compared to the emf voltage induced in the secondary coil 1. Therefore, the net output voltage will be

$$V_0 = V_1 - V_2 = -ve$$

Applications of LVDT:

- LVDT is used to measure displacement ranging from fraction millimetre to centimetre.
- Acting as a secondary transducer, LVDT can be used as a device to measure force, weight and pressure, etc.

2.5 Force Sensor (Load Cell)

2.5.1 Basic Principle of Strain gauge load cell: When steel cylinder is subjected to a force, it tends to change in dimension. On this cylinder, if the strain gauges are bonded, the strain gauge also is stretched or compressed, causing a change in its length and diameter. This change in dimension of the strain gauge causes its resistance to change. This change in resistance or output voltage of the strain gauge becomes a measure of applied force.

2.5.2 Construction

The main parts of the strain gauge load cell is shown in fig.211. They are a cylinder made up of steel on which four identical strain gauge are mounted and out of four strain gauges, two of them (R1 and R4) are mounted along the direction of the applied load (vertical gauges). The other two strain gauges (R2 and R3 Horizontal gauges) are mounted circumferentially at right angles to gauges R1 and R4.

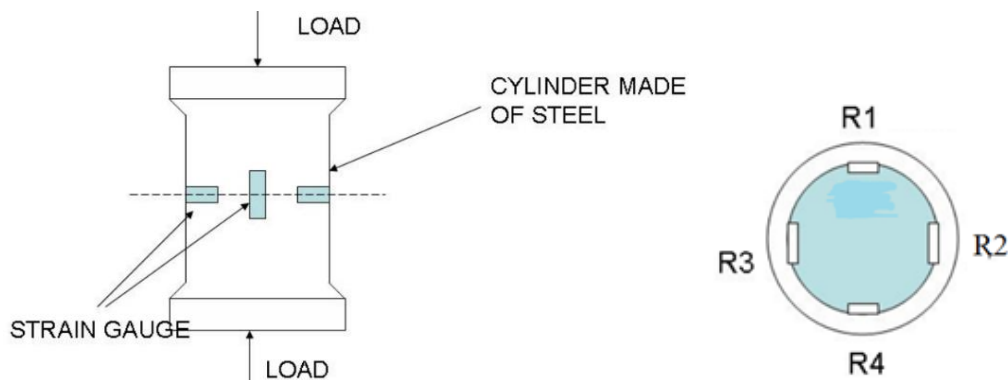
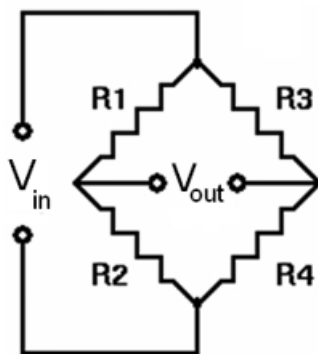

Fig. 2.11 Construction of Load Cell

2.5.3 Operation of strain gauge Load cell

These four gauges are connected in the form of bridge to convert the change in resistance to voltage as shown in fig. 2.12. the output voltage V_{out} is given by



$$V_{out} = \left(\frac{R_4}{R_3 + R_4} - \frac{R_2}{R_1 + R_2} \right) V_{in}$$

Fig.2.12 Wheatstone Bridge and its output voltage

Case 1: When there is no load (force) on the steel cylinder, all the four gauges will have the same resistance. Hence the wheat stone bridge is balanced and hence the output voltage will be zero.

$$V_{\text{out}} = 0$$

Case 2: Now the load (force) to be measured (say compression force) is applied on the steel cylinder. Due to this, the vertical gauges R1 and R4 will undergo compression and hence there will be a decrease in resistance. At the same time, the horizontal gauges R2 and R3 will undergo tension and there will be an increase in resistance. Thus, when strained, the resistance of the various gauges changes. Then the wheat stone bridge is unbalanced and hence the output voltage will not be zero.

$$V_{\text{out}} \neq 0$$

Now the change in output voltage due to the applied load (force) becomes a measure of the applied load force when calibrated.

Applications:

- Vehicle Weigh Bridges
- Too force dynamo meters
- Tension measurement of wires

2.6 Temperature Sensors

Detect or measure changes in temperature and converts into electrical signal. The types of temperature sensors as follows

- Bi-metallic strips(420⁰C)
- Thermocouples (-200⁰C to over +2000⁰C to be measured.)
- Resistance Temperature Detectors (RTDs) (-200 to +600⁰C.)
- Thermistors (-50- 200⁰C)
- Thermodiodes and thermotransistors (-50- 150⁰C)

2.6.1 Bi-metallic strips

Bonding two metals with dissimilar thermal expansion coefficients can produce useful devices for detecting and measuring temperature changes. A typical pair is brass and steel with typical expansion coefficients of 19 and 13 parts per million per degree Celsius respectively.

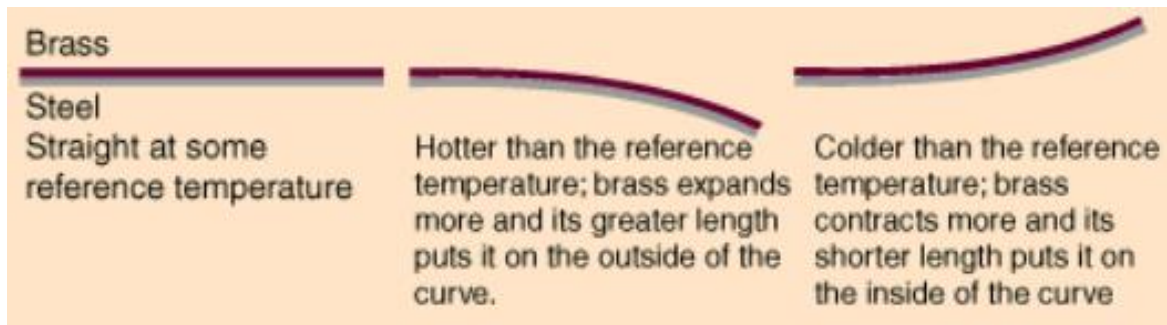

This principle is used in many applications. The most important application of bi-metallic strip as a thermal switch as shown in fig. 2.13

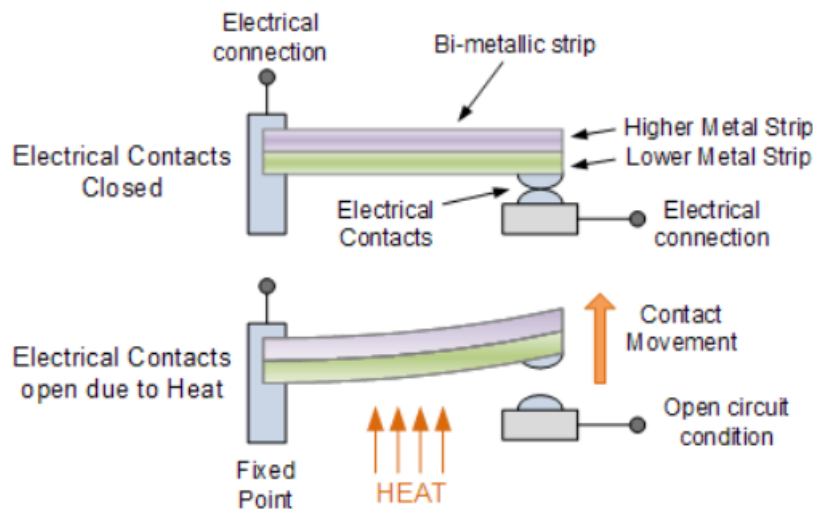

Fig.2.13 Thermal Switch

Advantages and disadvantages:

- Power source not required²
- Easy to use and cheap but not very accurate.
- Can be used to 500 °C
- Limited to applications where manual reading is acceptable, e.g. a household thermometer
- Not suitable for very low temperatures because the expansion of metals tend to be too similar, so the device becomes a rather insensitive thermometer

2.6.2 Resistance Temperature Detectors (RTD)

RTDs work on the principle that the electric resistance of a metal changes due to change in its temperature. On heating up metals, their resistance increases and follows a linear relationship as shown in Figure 2.5.2. The correlation is

$$R_t = R_0(1 + \alpha T)$$

Where R_t is the resistance at temperature T ($^{\circ}\text{C}$) and R_0 is the resistance at 0°C and α is the constant for the metal termed as temperature coefficient of resistance. The sensor is usually made to have a resistance of $100\ \Omega$ at 0°C

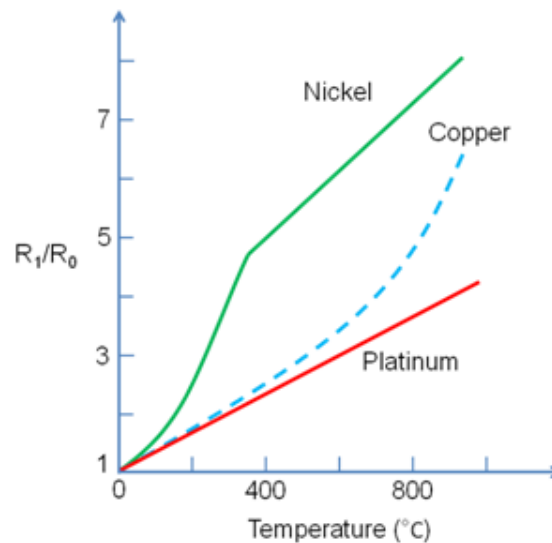

Fig.2.14 Variation of resistance with temperature for metals

Applications:

- Air conditioning and refrigeration servicing
- Food Processing
- Stoves and grills
- Textile production
- Plastics processing
- Petrochemical processing
- Micro electronics
- Air, gas and liquid temperature measurement in pipes and tanks
- Exhaust gas temperature measurement

2.6.3 Thermistors

Thermistor is a type of resistor used to measure temperature changes, relying on the change in its resistance with changing temperature. Thermistor is a combination of the words thermal and resistor. The symbol of thermistor is shown in fig.2.15

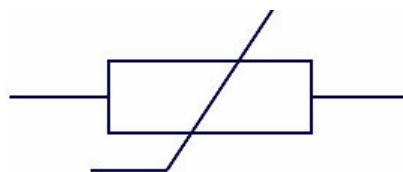

Fig. 2.15 The symbol of thermistor

A simple linear relationship between resistance and temperature is

$$\Delta R = k \Delta t$$

where ΔR = change in resistance

Δt = change in temperature

k = temperature coefficient of resistance

Commercially available thermistors have nominal values of 1K,2K,10K,20K,100K etc.,

Types of thermistors:

Negative temperature co-efficient (NTC) thermistors: These are Mixture of metal oxides such as chromium, cobalt, iron, manganese and nickel pressed into a bead, disc or rod shape.

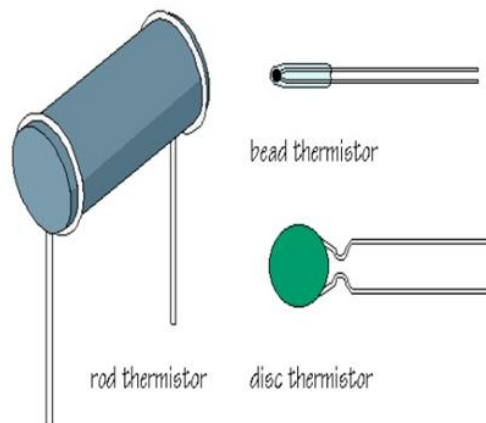

Positive temperature co-efficient (PTC) thermistors: Positive temperature co-efficient thermistors are made-up of barium, lead and strontium titanite. these have limited use and they are particularly used for protection of motors and transformer winding.

Characteristics of thermistors: Fig.2.16 shows characteristics of thermistors

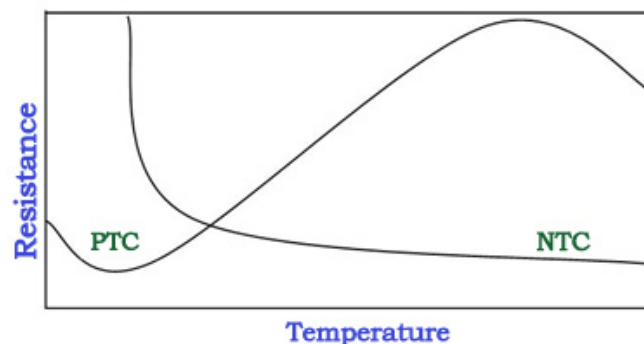

Fig.2.16 Characteristics of thermistors

2.6.4 Thermocouple

Thermocouple works on the fact that when a junction of dissimilar metals heated, it produces an electric potential related to temperature. As per Thomas Seebeck (1821), when two wires composed of dissimilar metals are joined at both ends and one of the ends is heated, then there is a continuous current which flow in the thermoelectric circuit. Figure 2.17 shows the

schematic of thermocouple circuit. The net open circuit voltage (the Seebeck voltage) is a function of junction temperature and composition of two metals. It is given by,

$$\Delta V_{AB} = \alpha \Delta T$$

Where α , the Seebeck coefficient, is the constant of proportionality.

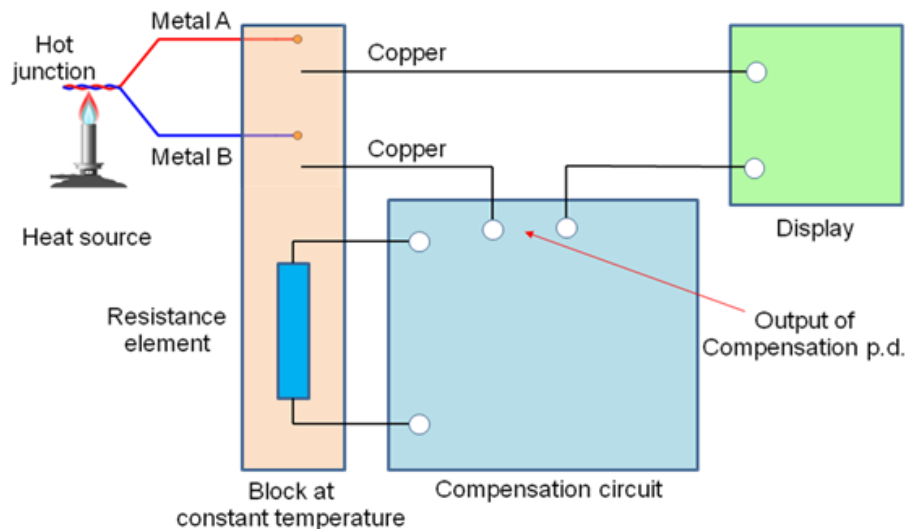

Fig. 2.17 Schematic of thermocouple circuit

Generally, Chromel(90% nickel and 10% chromium)–Alumel(95% nickel, 2% manganese, 2% aluminium and 1% silicon) are used in the manufacture of a thermocouple.

Applications of Thermocouples

- To monitor temperatures and chemistry throughout the steel making process
- Testing temperatures associated with process plants e.g. chemical production and petroleum refineries
- Testing of heating appliance safety
- Temperature profiling in ovens, furnaces and kilns
- Temperature measurement of gas turbine and engine exhausts
- Monitoring of temperatures throughout the production and smelting process in the steel, iron and aluminium industry

2.6.5 Thermodiodes and thermotransistors

A junction semiconductor pn junction diode is widely used as temperature sensor. When temperature of doped semiconductor changes the mobility of their charge carries changes and this effect the rate at which electrons and holes can diffuse across a pn junction. Thus, when pn junction diode as potential difference V across it. The current through the junction is a function of the temperature and is given by

$$I = I_0 \left(e^{\frac{V_D}{V_T}} - 1 \right) = I_0 \left(e^{\frac{qV_D}{KT}} - 1 \right)$$

After applying natural logarithm on both sides

$$\frac{qV_D}{KT} = \ln \left(\frac{I}{I_0} + 1 \right)$$

$$V_D = \frac{KT}{q} \ln \left(\frac{I}{I_0} + 1 \right)$$

Where temperature on kelvin scale.

Thus, for a constant, current we have V_D is proportional to the temperature on kelvin scale. So measurement of the potential difference across the diode for a constant current can be used as measure of temperature, such sensor is compact like thermistor and as the great advantage of giving a response which is linear function of temperature. Diodes for use of temperature sensor, together with necessary signal conditioning are supplied as integrated circuit eg. LM3911 and give very compact sensor. The output voltage from LM3911 is proportional to temperature at the rate $10\text{mV}/^\circ\text{C}$.

In similar manner to the thermodiode, for a thermotransistor the voltage across the junction between the base and emitter depend on the temperature and can be used as a measure of temperature. A common method is to use two transistors with different collector current and determine the difference in the base emitter voltage between them, this difference is proportional to the temperature on kelvin scale. Such transistor with necessary signal conditioning are supplied as integrated circuit eg. LM35 and give very compact sensor.

LM35: Integrated-circuit temperature sensor with an output voltage linearly-proportional to the Centigrade temperature and is shown in fig. 2.18

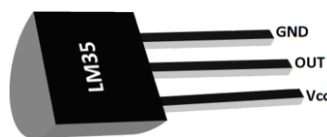

Fig. 2.18 LM35 Temperature sensor

Features:

- Calibrated Directly in Celsius (Centigrade)
- Linear $\pm 10\text{mV}/^\circ\text{C}$ Scale Factor
- 0.5°C Ensured Accuracy (at 25°C)
- Rated for Full -55°C to 150°C Range
- Suitable for Remote Applications
- Low-Cost

- Operates from 4 V to 30 V
- Less than 60- μ A Current Drain
- Non-Linearity Only $\pm 1/4^\circ\text{C}$ Typical
- Low-Impedance Output, 0.1 Ω for 1-mA Load

Applications:

- Air conditioners (AC)
- Incubators
- Microwave ovens
- Poly houses
- Poultry forms

2.7 Light Sensors

Light sensors are devices that are used to convert light energy into electrical energy. The commonly used sensors are

- Light Dependent Resistor (LDR)
- Photo Diode
- Photo transistor

2.7.1 Light Dependent Resistor (LDR)

LDR is a device whose resistance is a function of amount of light falling on it. This is also called as Photoresistor, Photoconductor, Photoconductive cell or simply Photocells.

Construction: Made up of with semiconductor materials having high resistance. Like cadmium sulphide, lead sulphide (PbS), lead selenide (PbSe), indium antimonide (InSb). Cadmium sulphide is used in the manufacture of photoconductive cells because its spectral response curve closely matches that of the human eye and can even be controlled using a simple torch as a light source. The LDR and its symbols are shown in fig. 2.19

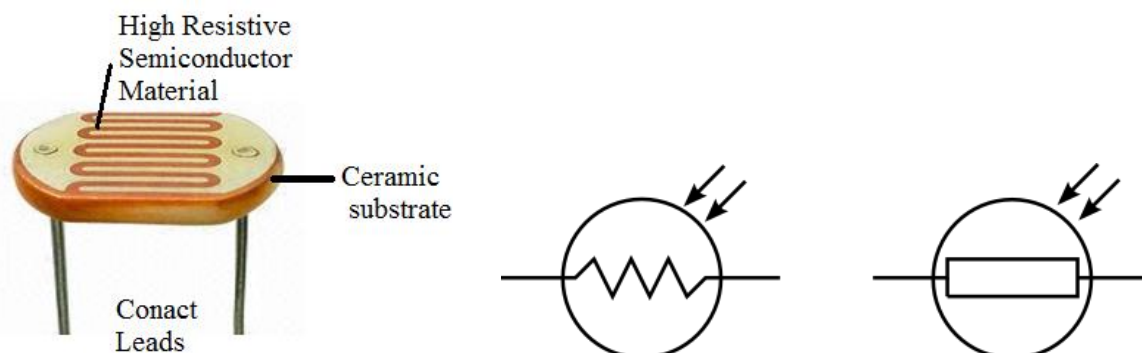

Fig. 2.19 Construction of LDR

LDR Symbols

Working principle: Photo conductivity is an optical phenomenon in which the materials conductivity is increased when light is absorbed by the material. When photon of energy $h\nu \geq E_g$ Incident on the semiconductor material. The electrons in the valance band gains the energy and exited to conduction band as shown in fig. 2.20. This process results in a greater number of carriers in the conduction band. Hence the conductivity of semiconductor material is increased. When there is no light, the resistance on the device is known as Dark Resistance. This is of the order of several M Ω .

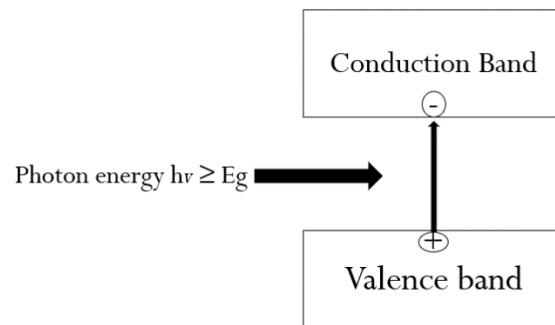

Fig.2.20 Photo conductivity

Characteristics of LDR: The characteristics of LDR is shown in fig.2.21.

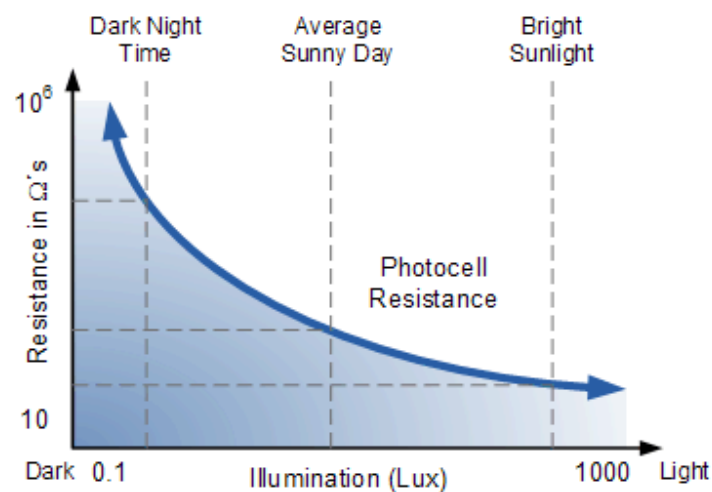

Fig.2.21 Characteristics of LDR

Applications:

- Automatic Street light systems
- Bar code Scanners
- Counting packages
- Light Intensity Meters
- Burger Alarms

2.7.2 Photodiode

A photodiode is a type of photo detector capable of converting light energy into electrical energy. It is sometimes referred as photo-detector, photo-sensor, or light detector. The symbol of photodiode is shown in fig. 2.22

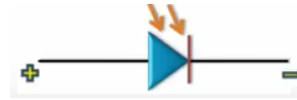

Fig.2.22 Symbol of Photodiode

Photodiodes are like regular semiconductor diode except that they may be either exposed (to detect UV or X-rays) or packaged with a window or optical fiber to allow light to reach the sensitive part of the device. They are made up with compounds of semiconductor materials like GaAs and InGaAs

Photodiodes are classified into three types, they are

- a) PN Photodiode
- b) PIN Photodiode
- c) Avalanche Photodiode.

PN Junction Photodiode: A photodiode is designed to operate in reverse bias as shown in fig. When there is no light a small reverse saturation current is flowing due to thermally generated minority charge carriers. The current in the circuit is known as Dark Current.

When light energy is supplied to photodiode, the valence electrons in the depletion region gain the energy and come out from the atom. Hence new electron-hole pairs are created in the depletion region. The mechanism of generation of new electron-hole pairs by using light energy is known as photo electric effect and the carriers are called Light generated carriers or phot carriers. These carriers constitute a current in the external circuit and is known as Photo Current. The current flowing through the photodiode is directly proportional to the incident number of photons as shown in fig.2.23

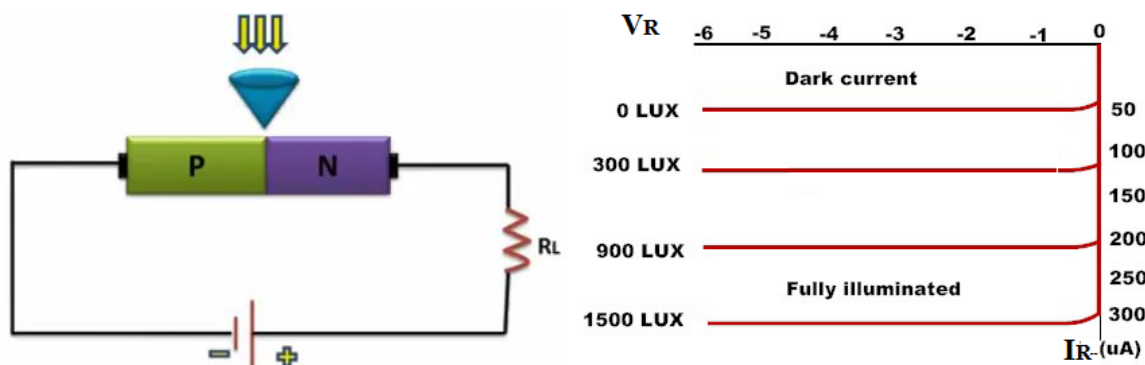

Fig.2.23 Photodiode

VI Characteristics

Characteristics: The characteristics of Photodiode is shown in fig.2.24

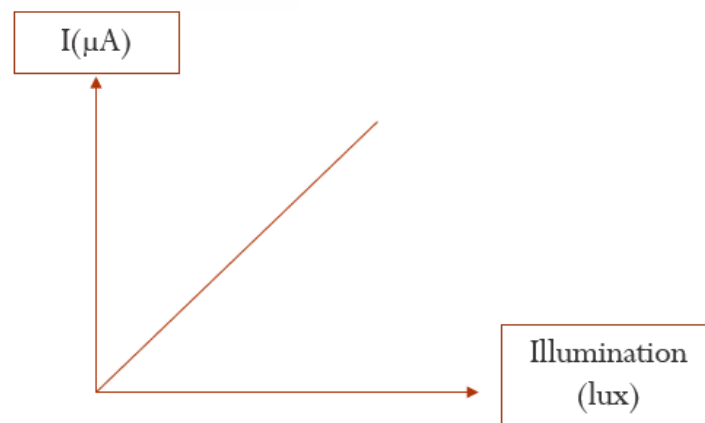

Fig.2.24 Characteristics of Photodiode

Applications:

- CD Players
- Smoke detectors
- Space Applications
- Optical Communication

2.7.3 Phototransistor

Phototransistors are either tri-terminal (emitter, base and collector) or bi-terminal (emitter and collector) semiconductor devices which have a light-sensitive base region. Although all transistors exhibit light-sensitive nature, these are specially designed and optimized for photo applications. These are made of diffusion or ion-implantation and have much larger collector and base regions in comparison with the ordinary transistors. These devices can be either homojunction structured or heterojunction structured, as shown by Fig. 2.25 a and b, respectively.

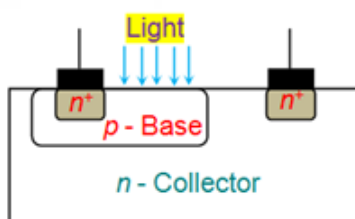

Fig. 2.25 (a) Homojunction

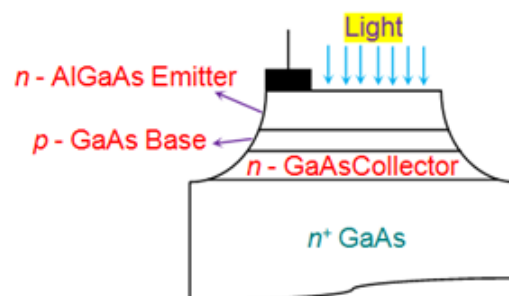

Fig. 2.25 (b) Heterojunction

Applications:

- CD Players
- Smoke detectors

- Space Applications
- Optical Communication

In the case of homojunction phototransistors, the entire device will be made of a single material-type; either silicon or germanium. However to increase their efficiency, the phototransistors can be made of non-identical materials (Group III-V materials like GaAs) on either side of the pn junction leading to heterojunction devices. Nevertheless, homojunction devices are more often used in comparison with the hetero junction devices as they are economical.

The circuit symbol for npn phototransistors is shown by Figure 2.26 which is nothing but a transistor (with or without base lead) with two arrows pointing towards the base indicating its sensitivity to light. Similar symbolic representation holds well even in the case of pnp phototransistors with the only change being the arrow at emitter pointing in, instead of out.



Fig. 2.26 (a) Tri-terminal

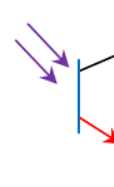

Fig. 2.26 (b) Bi-terminal

Principle of Working: The collector current equation of a transistor is given by

$$I_C = \beta I_B + (1 + \beta)I_{CBO}$$

In phototransistor the base is open that is $I_B = 0$, then above equation becomes

$$I_C = (1 + \beta)I_{CBO}$$

In photodetector, I_{CBO} is increased when collector base junction is illuminated by light. When I_{CBO} is increased the collector, current is also increased for a given amount of illumination. Thus, phototransistor is a light detector which is combines photodiode and transistor amplifier.

Applications:

1. Monitoring paper position and margin in printers
2. Punch card readers
3. CD players
4. Night vision light systems
5. Counting coins and other items
6. Security systems

2.8 Proximity Sensors:

A proximity sensor is sensor able to detect the presence of nearby objects without any physical contact. Proximity sensors often emits an electromagnetic field or beam of electromagnetic radiation(infrared) and looks for change in the field or return signal. The object being sensed is often referred to the proximity sensor target. Types of proximity sensors

- Inductive
- Capacitive
- Optical
- Ultrasonic

2.8.1 Inductive proximity sensor

An Inductive proximity sensor is a type of non-contact electric proximity sensor that is used to detect the presence and position of metallic objects. Inductive proximity sensor is shown in fig. 2.27. Their operating principle is based on a coil and high frequency oscillator that creates a field in the close surroundings of the sensing surface. The presence of metal in the operating area causes a change in the oscillation amplitude. This change is identified by a threshold circuit, which changes the output of the sensor. The operating distance of the sensor depends on the coil's size as well as the target's shape, size and material. The sensing range is rarely greater than 6 cm, however, and it has no directionality.

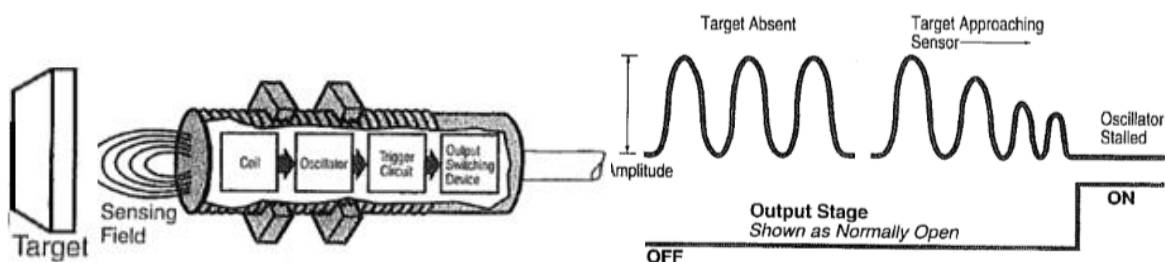

Fig.2.27 Inductive proximity sensor

Applications:

- Common applications of inductive sensors include metal detectors, car washes, and a host of automated industrial processes.
- Because the sensor does not require physical contact it is particularly useful for applications where access presents challenges or where dirt is prevalent.

2.8.2 Capacitive proximity sensor

Capacitive sensors are used for non-contact detection of metallic objects & non-metallic objects (liquid, plastic, wooden materials and so on). Capacitive proximity sensor is shown in

fig. 2.28. Capacitive proximity sensors use the variation of capacitance between the sensor and the object being detected. When the object is at a preset distance from the sensitive side of the sensor, an electronic circuit inside the sensor begins to oscillate. The rise or fall of such oscillation is identified by a threshold circuit that drives an amplifier for the operation of an external load.

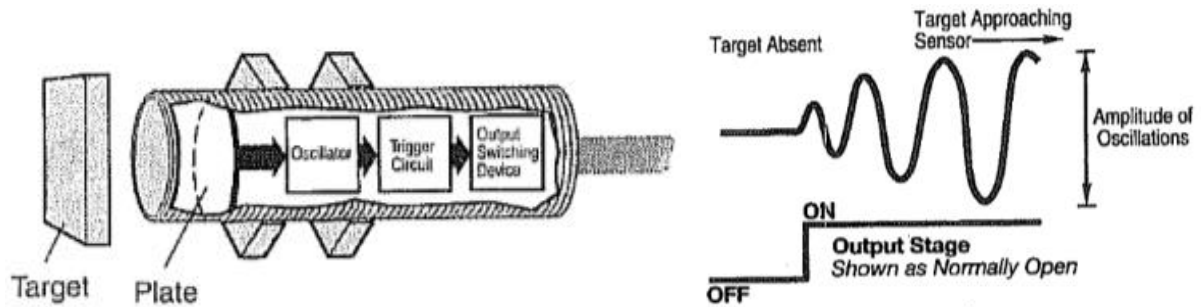

Fig. 2.28 Capacitive proximity sensor

Applications:

- Capacitive touch sensors are used in many devices such as laptop track pads, digital audio players, computer displays, mobile phones, mobile devices and others.
- More and more design engineers are selecting capacitive sensors for their versatility, reliability and robustness and cost reduction over mechanical switches.

2.8.3 Optical proximity sensor

Optical proximity sensors generally cost more than inductive proximity sensors, and about the same as capacitive sensors. They are widely used in automated systems because they have been available longer and because some can fit into small locations. These sensors are classified into three types

- Through beam
- Diffuse reflective
- Retroreflective

These optical sensors are shown in fig. 2.29

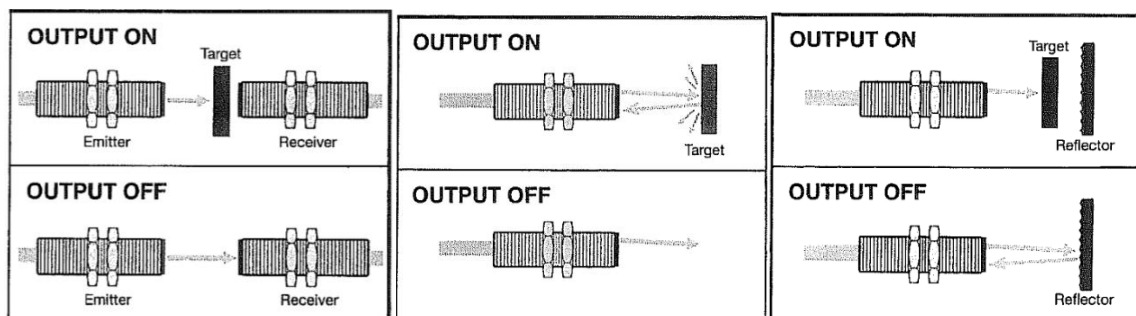

Fig.2.29 (a) Through beam Fig. (b) Diffuse reflective Fig. (c) Retroreflective

In all types of sensor if output is ON only object is present otherwise output is OFF.

2.8.4 Ultrasonic proximity sensor

Ultrasonic sensors are sometimes used in place of optical sensors. Instead of using an light beam, a high frequency sound wave is used. This sound wave is above normal hearing frequencies and are called ultrasonic. Frequencies around 40KHz are common.

- Subsonic sound: 20Hz
- Sonic Sound :20-20KHz
- Ultrasonic Sound: > 20KHz

Working: The sensor first emits a short Ultrasonic Pulse

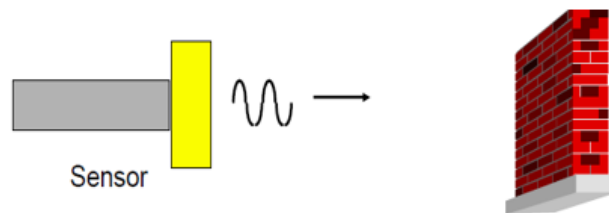

and waits for the echo.

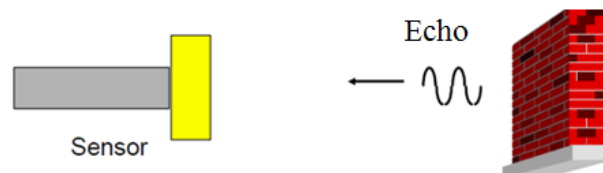

When echo is returned, the sensor detects the target is present and by measuring the time delay between transmitted pulse and the return echo the sensor calculates the distance between sensor and the object.

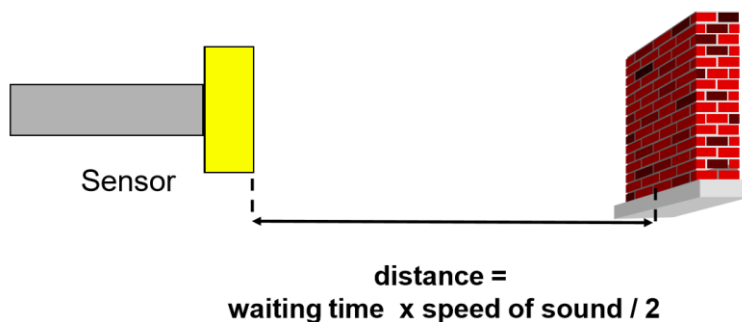

Applications:

- Ultrasonic sensors can measure the distance to a wide range of objects
- Liquid Level Control/Monitoring
- Trash Level Monitoring
- Uses in Production Lines
- Vehicle Detection for Car Washes, Automotive Assembly, and Parking Garage

UNIT -III ACTUATORS

3.0 Actuators

An Actuator is a device which converts electrical energy into physical energy or an actuator is a component of a machine that is the drives the mechanism or system. The actuators basically classified into two types

➤ Electrical actuators

Ex: Relays, Solenoids

Solid-state switches: Diodes, transistors, MOSFETS, thyristors

Drive systems: -DC, AC, or stepper motors

➤ Mechanical actuators

Ex: Gears, Belt and chain drives and bearings etc.,

3.1 Relay

A relay is an electrically operated switch. It is also called as electromagnetic or electromechanical switch. The heart of a relay is an electromagnet: a coil of wire that becomes a temporary magnet when electricity flows through it. Relay consists of four elements and it is shown in Fig.3.1

- Electromagnet
- Movable armature
- Contacts and
- Spring.

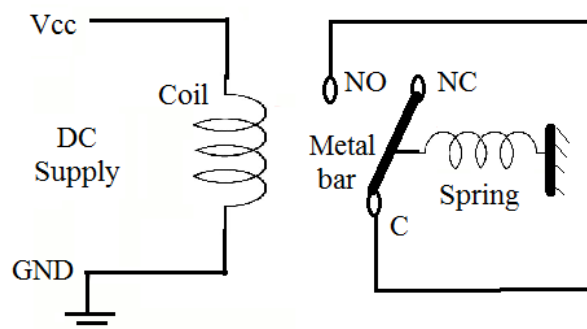

Fig. 3.1 Relay showing its components

3.1.1 Working

When a small current flow in the input circuit, it activates the electromagnet as shown in fig.3.2, which produces a magnetic field all around it. The energized electromagnet pulls the

metal bar in the output circuit toward it, closing the switch and allowing a much bigger current to flow through the output circuit.

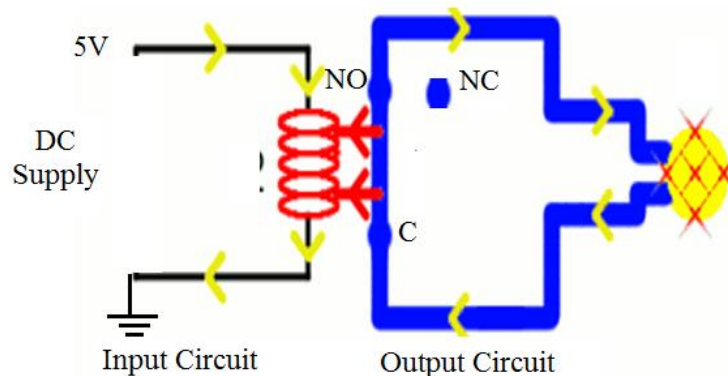

Fig. 3.2 Relay is under DC supply as input

When we remove power supply to the coil, the coil will be demagnetized, the movable armature get back to its original position because of spring action as shown in fig. 3.3. The output circuit operates a high-current appliance such as a lamp or an electric motor.

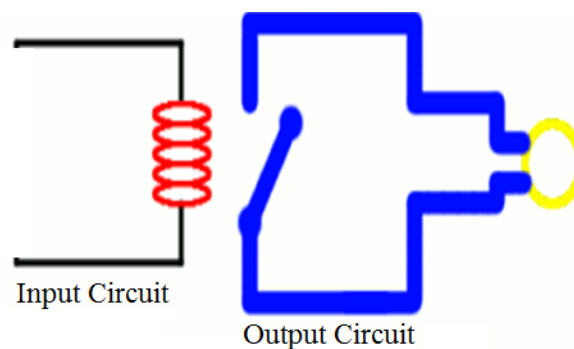

Fig. 3.2 Relay is under no input

3.1.2 Types of Relays

Relays are basically classified into four type as shown in fig. 3.4.

- Single Pole Single Through (SPST)
- Single Pole Double Through (SPDT)
- Double Pole Single Through (DPST)
- Single Pole Single Through (DPDT)

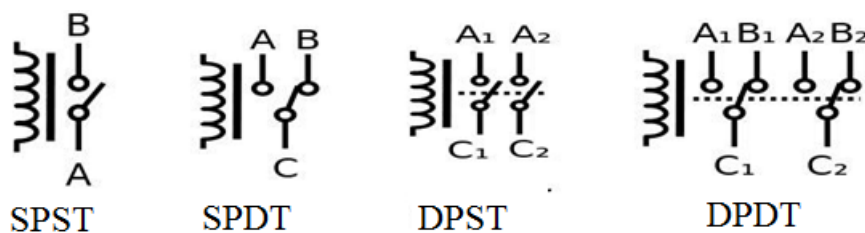

Fig. 3.4 Types of relays

3.1.3 Applications

- Home appliances- A.C, Refrigerator, Oven
- Automobiles- Car head lights, viper
- Industrial plant control-Boilers, furnace

Basic Uses of relays:

- Control of High power circuits using low input power
- Control two or more circuits using single input.

3.2 Solenoid

Solenoid is a insulated copper coil is wound around some cylindrical cardboard or plastic tube such that the length of the coils is greater than its diameter, then it becomes like a magnet.

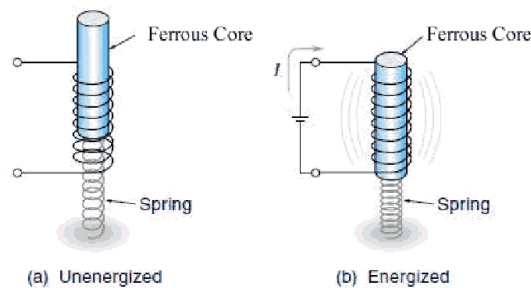

Fig. 3.5 Solenoid working

3.2.1 Working

Solenoid is an electromagnetic device made up of a coil which produces a magnetic field when electric current passed through it, then it is energized and attracts the ferrous core as shown in figure 3.5(b). if supply is removed the coil is un-energized and releases the ferrous core as shown in figure 3.5(a). Such solenoids are used in relaying energy from one device to another. such solenoids are used mainly in opening and closing valves as shown in figure 2. Solenoid valves When the solenoid coil is energized, the valve opens, allowing water to flow from the reservoir into the fish tank. otherwise, valve is closed.

3.2.2 Applications

- Robots,
- Open and close of car doors
- Dish washes
- Liquid/gas flow control (Solenoid valves)
- Solenoid engines.

3.2.3 Solenoid valves

Figure 3.6 shows Solenoid valves, which can control the flow of liquid.

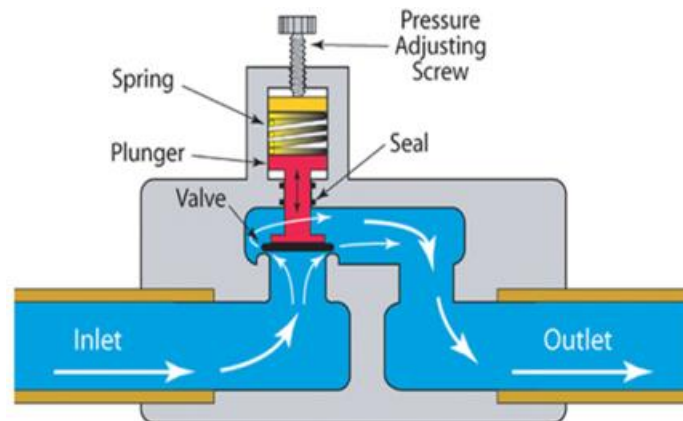

Fig. 3.6 Solenoid valves

3.3 Solid-State switches

Solid-State switches are made up of with semiconductor material. The commonly use Solid-State switches are Diodes, transistors, MOSFETS, thyristors etc.,.

3.3.1 Diode

A pure silicon crystal or germanium crystal is known as an intrinsic semiconductor. There are not enough free electrons and holes in an intrinsic semi-conductor to produce a usable current. The electrical action of these can be modified by doping means adding impurity atoms to a crystal to increase either the number of free holes or no of free electrons. When a crystal has been doped, it is called a extrinsic semi-conductor. They are of two types

- n-type semiconductor having free electrons as majority carriers
- p-type semiconductor having free holes as majority carriers

A junction is made by joining p-type semiconductor to n-type semiconductor a useful device is produced known as diode and it is shown in fig. 3.7. It will allow current to flow through it only in one direction. The unidirectional properties of a diode allow current flow when forward biased and disallow current flow when reversed biased.

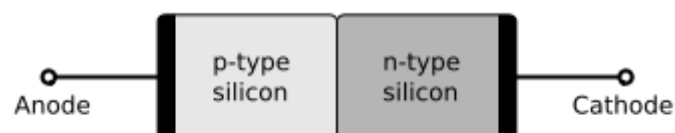

Fig.3.7 PN Junction diode

Formation of Depletion Region or (Open circuited PN Junction): The open circuited pn junction diode is shown in fig. 3.8. In a P-N junction, there exists a concentration gradient near the junction. There is large number of holes on N side, near the junction. Those holes start

moving from P side to N side i.e. from high concentration area to low concentration area. This is nothing but diffusion of holes from P side to N side. Similarly, the electrons on N side start diffusing across the junction into the P region.

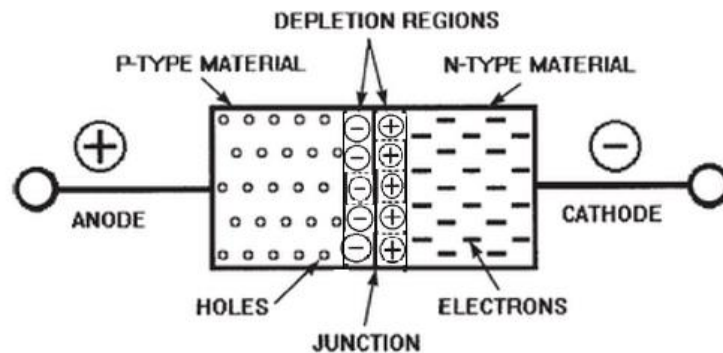

Fig. 3.8 Open circuited PN Junction

As holes enter the N region, they find number of donor atoms. The holes recombine with donor atoms. As donor atoms accept additional holes, they become positively charged immobile ions. Atoms on P side are acceptor atoms. The electrons diffusing from N side to P side recombine with the acceptor atoms on P side. As acceptor atoms accept additional electrons, they become negatively charged immobile ions. Such a large number of negatively charged ions get formed near the junction on P side.

As more number of holes diffuses on N side, large positive charge will be accumulated on N side near the junction. Eventually in the same way large negative charge will be accumulated on P side near the junction. Such a region is depleted of free mobile charge carriers and hence it is called “depletion region” or “depletion layer”. The depletion region is also called “space charge region” if the depletion region can become widened up to a point where no further electrons are holes can cross the junction. Thus, depletion region can acts as the barrier.

P-N Junction Diode: The P-N junction forms a popular semiconductor device called “P-N Junction Diode”. The P-N Junction has two terminals called as electrodes: one each from P region and N region. As there are two electrodes, it is called as diode i.e. di + electrode. The terminal connected to p-region is called Anode and the terminal connected to n-region is called cathode. The symbol of pn junction diode is shown in fig. 3.9



Fig. 3.9 Symbol of pn junction diode

We can connect the diode in circuits in two ways. This is also called as biasing which means applying an external voltage. The biasing is of two types

- Forward biasing
- Reverse biasing

Forward Biased PN Junction Diode:

If an external voltage is connected in such a way that the P region terminal is connected to the positive of DC voltage and the N region is connected to the negative of the DC voltage, the biasing condition is called forward biasing. The forward biased pn junction is shown in fig.3.10.

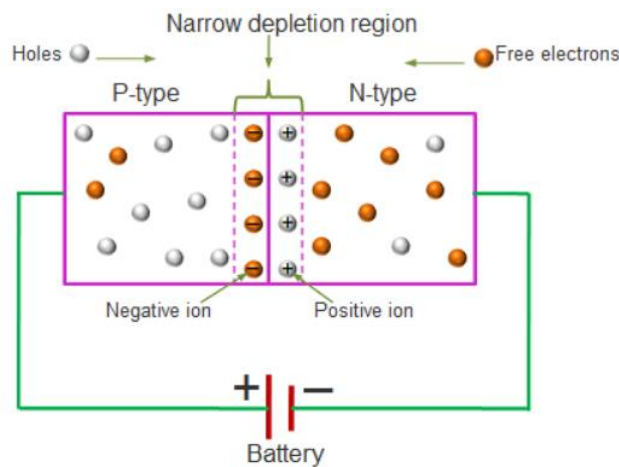

Fig.3.10 Forward biased PN Junction

When we apply an external voltage more than the barrier potential, the negative terminal of battery pushes the electrons against barrier from N to P region. Similarly, positive terminal pushes the holes from P to N region. Thus, holes get repelled by positive terminal and cross the junction against barrier potential. This reduces the width of depletion region. As forward voltage increased, at a particular value the depletion region becomes zero such that large number of charge carriers can cross the junction, hence current starts flowing through the diode and it is shown in fig. 3.12. The voltage at which the diode starts conducting is known as cut-in voltage or threshold voltage or knee voltage. The cut -in voltage for silicon diode is 0.7V and for germanium diode is 0.3V. Assuming current flowing through the diode to be very large, the diode can be approximated as short- circuited switch.

Reverse Biased PN Junction Diode:

When a diode is connected in a Reverse Bias condition, a positive voltage is applied to the N-type material and a negative voltage is applied to the P-type material.

The positive voltage applied to the N-type material attracts electrons towards the positive electrode and away from the junction, while the holes in the P-type end are also

attracted away from the junction towards the negative electrode. The net result is that the depletion layer grows wider due to a lack of electrons and holes and presents a high impedance path, almost an insulator. The result is that a high potential barrier is created thus preventing current from flowing through the semiconductor material. But due to minority charge carriers a small current called reverse saturation current continues to flow in the diode and which is of the order of micro-amperes, (μA). This current is negligible; the diode can be approximated as an open circuited switch.

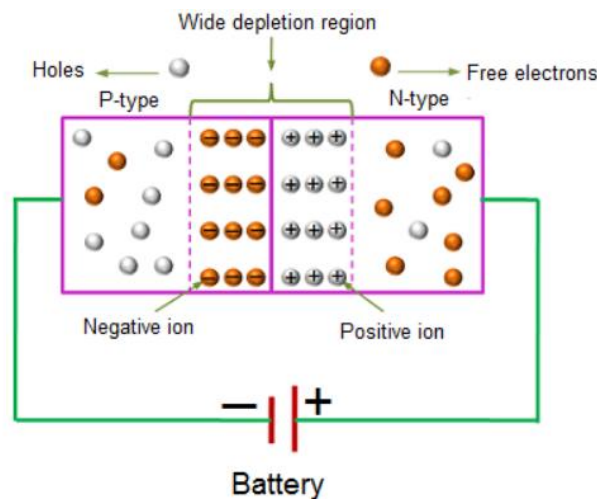

Fig.3.11 Reverse biased PN Junction

V-I Characteristics of PN Junction Diode: The volt- Ampere characteristics of pn junction diode is shown in fig.3.12.

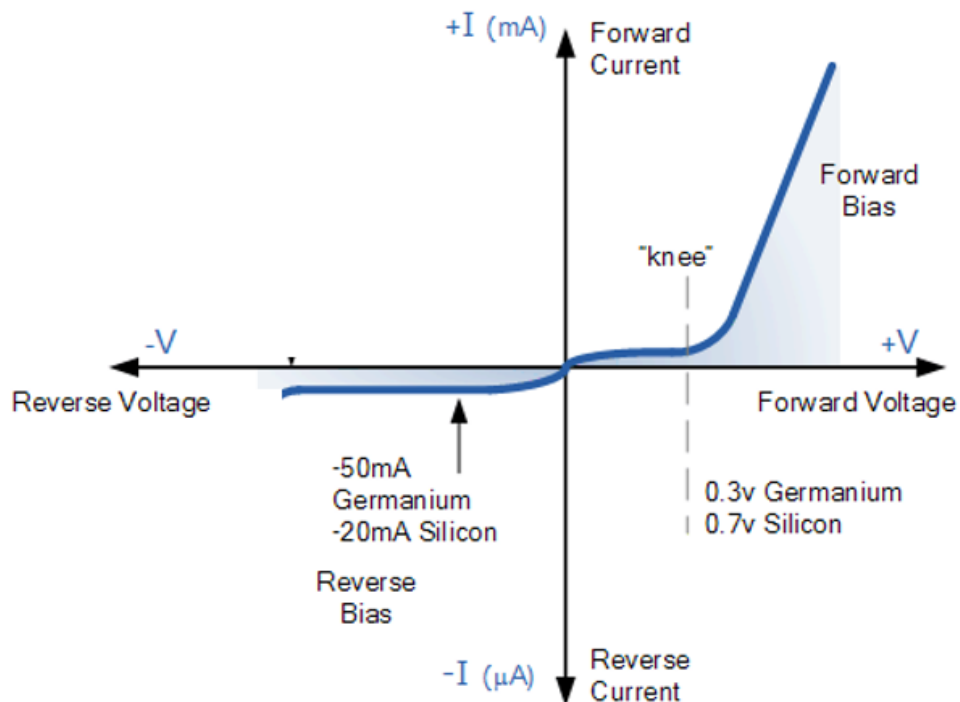

Fig.3.12 V-I Characteristics of PN Junction Diode.

Applications: A p-n junction diode allows electric current when it is forward biased and blocks electric current when it is reverse biased.

- Rectifier circuits
- Used as Switch
- Demodulator circuits
- Clipper and clamper circuits

3.3.2 Bipolar Junction Transistor (BJT)

A transistor is basically a Si or Ge crystal containing three separate regions. It can be either NPN or PNP type. The middle region is called the base and the outer two regions are called emitter and the collector.

In transistors, emitter is heavily doped. Its job is to emit or inject electrons into the base. These bases are lightly doped and very thin, it passes most of the emitter-injected electrons on to the collector. The doping level of collector is intermediate between the heavy doping of emitter and the light doping of the base.

The collector is so named because it collects electrons from base. The collector is the largest of the three regions; it must dissipate more heat than the emitter or base. The transistor has two junctions. One between emitter and the base and other between the base and the collector. Because of this the transistor is similar to two diodes, one emitter base diode and other collector base diode.

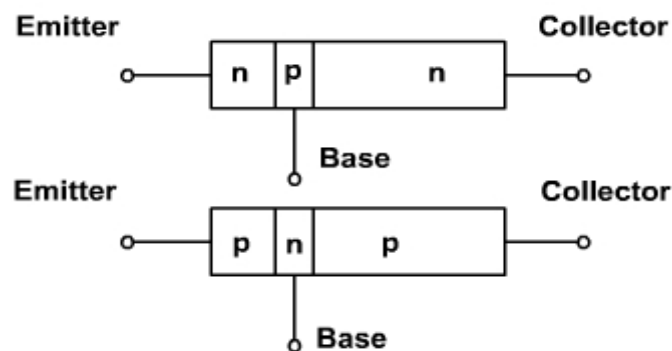

Operating Modes of Transistors:

Depends on the biasing conditions like forward or reverse, transistors have three major modes of operation namely cut-off, active and saturation regions.

Active Mode

In this mode transistor is generally used as a current amplifier. In active mode, emitter-base junction is forward biased whereas collector-base junction is reverse biased. In this mode, the current flows between emitter and collector and amount of current flow is proportional to the base current.

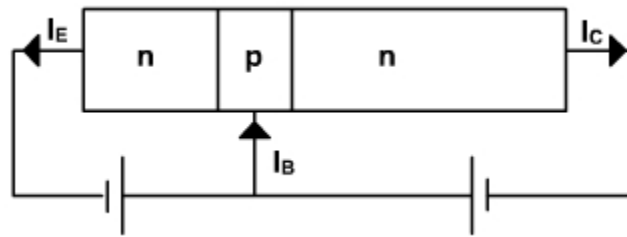

Cut-off Mode

In this mode, both collector base junction and emitter base junction are reverse biased. This in turn not allows the current to flow from collector to emitter when the base-emitter voltage is low. In this mode device is completely switched off as the result the current flowing through the device is zero. Hence in this mode transistor is acting as open switch.

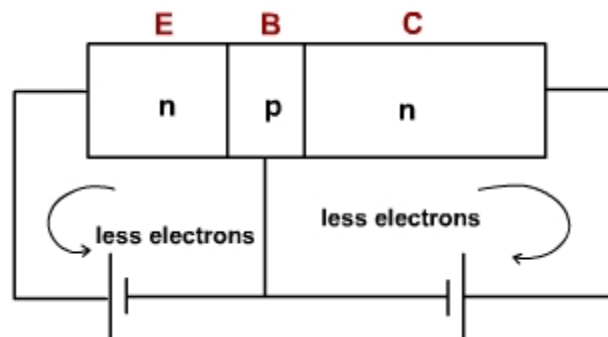

Saturation Mode

In this mode of operation, both the emitter base and collector base junctions are forward biased. Current flows freely from collector to emitter when the base-emitter voltage is high. In this mode device is fully switched ON. Hence in this mode transistor is acting as closed switch.

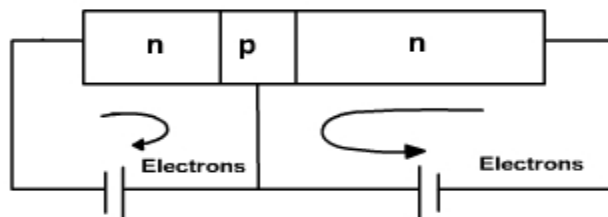

Characteristics of Transistors:

The figure 3.13 shows the output characteristics of a BJT Transistor. In the figure 3.13 cutoff region has the operating conditions as zero collector output current, zero base input current and maximum collector voltage. These parameters cause a large depletion layer which further doesn't allow current to flow through the transistor. Therefore, the transistor is completely in OFF condition.

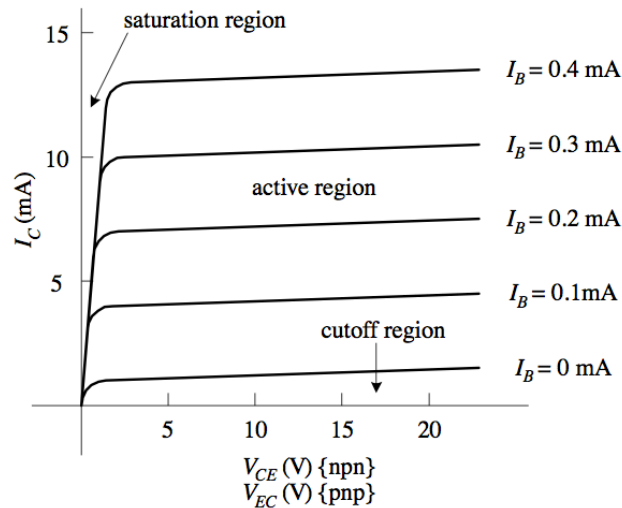

Fig.3.13 CE output Characteristics

Similarly, in the saturation region, a transistor is biased in such a way that maximum base current is applied that results maximum collector current and minimum collector-emitter voltage. This causes the depletion layer to become small and to allow maximum current flow through the transistor. Therefore, the transistor is fully in ON condition.

Hence, the transistors can be made to work as ON/OFF solid-state switch by operating transistor in cutoff and saturation regions. This type of switching application is used for controlling motors, lamp loads, solenoids, etc.,.

Transistor is operated in three configuration and comparison of configuration are given in below table

Property	Common Base	Common Emitter	Common Collector
Input resistance	Low	moderate	high
Output resistance	high	moderate	Low
Current gain	1	high	high
Voltage gain	About 150	About 500	Less than 1
Phase shift	0 or 360	180	0 or 360
Applications	For high frequency circuits	For audio frequency circuits	For impedance matching

Transistor Applications:

- Amplifiers, Oscillators
- Used as a Switch.

Transistor as a Switch:

Transistor will become ON (saturation) when a sufficient voltage V is given to input. During this condition the Collector Emitter voltage V_{ce} will be approximately equal to zero, i.e., the transistor acts as a short circuit. For a silicon transistor it is equal to 0.3v. Thus, collector current $I_c = V_{cc}/R_c$ will flows. This is shown in fig. 3.14

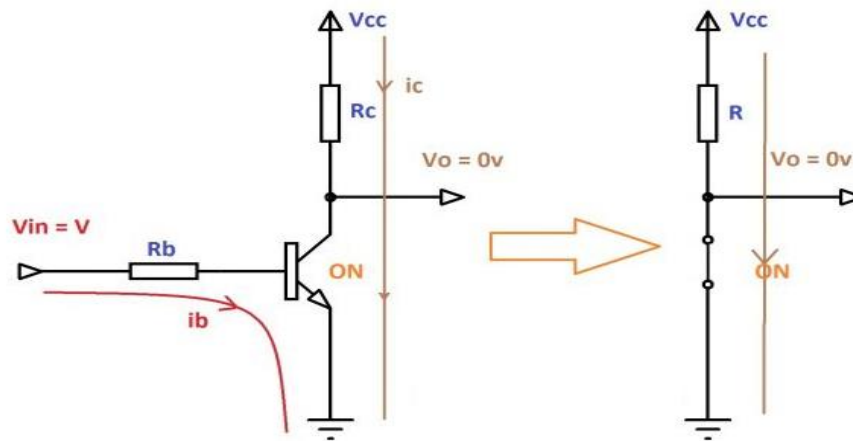

Fig. 3.14 Transistor as Closed Switch

Transistor will be in OFF (cutoff) when the input V_{in} equal to zero. During this state transistor acts as an open circuit and thus the entire voltage V_{cc} will be available at collector. This is shown in fig. 3.15

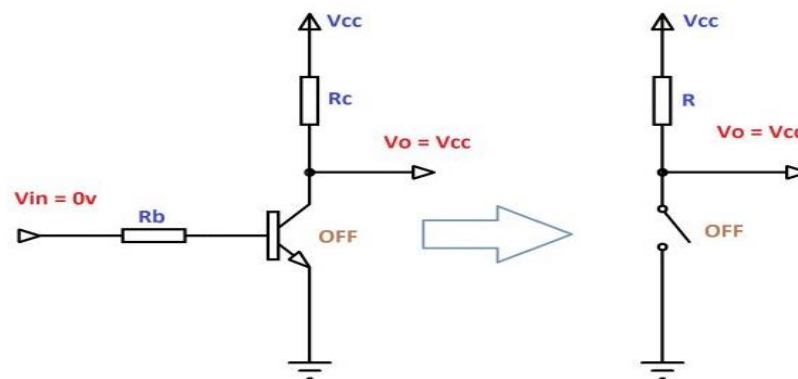

Fig. 3.15 Transistor as open Switch

3.3.3 MOSFET – Metal Oxide Field Effect Transistor.

The MOSFET (Metal Oxide Semiconductor Field Effect Transistor) transistor is a semiconductor device which is widely used for switching and amplifying electronic signals in the electronic devices. The MOSFET is a three terminal device such as source, gate, and drain. The MOSFET is very far the most common transistor and can be used in both analog and digital circuits

The MOSFET works by varying the width of a channel along which charge carriers flow (holes and electrons). The charge carriers enter the channel from the source and exits through the drain. The channel width is controlled by the voltage on an electrode is called gate which is located between the source and drain. It is insulated from the channel near an extremely thin layer of metal oxide.

Types of MOSFET Devices

The MOSFET is classified into two types such as

- Depletion-type MOSFET or DE-MOSFET: The DE-MOSFET can be operated in both depletion mode and the enhancement mode. For this reason, it is also called depletion/enhancement MOSFET.
- Enhancement-type MOSFET or E-MOSFET: The E-MOSFET can be operated only in enhancement mode.

MOSFET Working Principle:

The construction of MOSFET is shown in fig. 3.16. The working of MOSFET depends upon the metal oxide capacitor (MOS) that is the main part of the MOSFET. The oxide layer presents among the source and drain terminal. It can be set from p-type to n-type by applying positive or negative gate voltages respectively. When apply the positive gate voltage the holes present under the oxide layer with a repulsive force and holes are pushed downward through the substrate. The deflection region populated by the bound negative charges which are allied with the acceptor atoms.

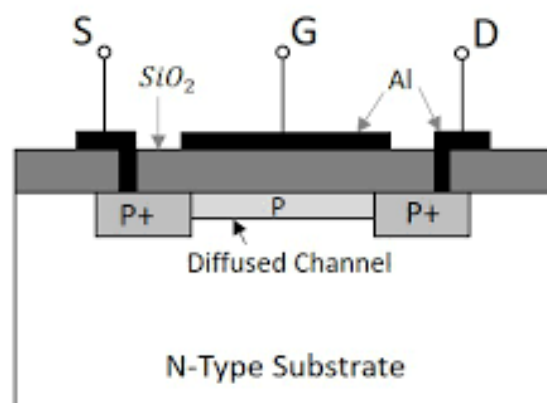

Structure of P-channel MOSFET

Fig. 3.16 Construction of MOSFET

Enhancement Type MOSFET:

The Enhancement type MOSFET is also further classified into two types, they are n-channel and p-channel and symbols are shown in below The figure 3.symbols for n-channel E-MOSFET and the schematic symbol for p-channel E-MOSFET.

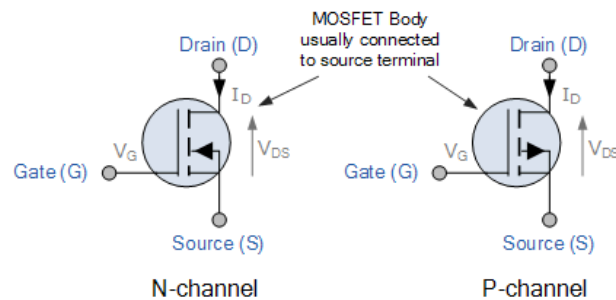

The E-MOSFET has no channel between source and drain. The substrate extends completely to the SiO_2 layer so that no channel exists. The E-MOSFET requires a proper gate voltage to form a channel, called induced channel between the source and the drain. It operates only in the enhancement mode and has no depletion mode.

Only by applying V_{GS} of proper magnitude and polarity, the device starts conducting. The minimum value of V_{GS} of proper polarity that turns on the E-MOSFET is called *threshold voltage* [$V_{GS(th)}$]. The n-channel MOSFET requires positive V_{GS} ($\geq V_{GS(th)}$) and the p-channel MOSFET requires negative V_{GS} ($\geq V_{GS(th)}$).

Circuit Operation of E-MOSFET

The circuit of n-channel E-MOSFE. The circuit action is as under:

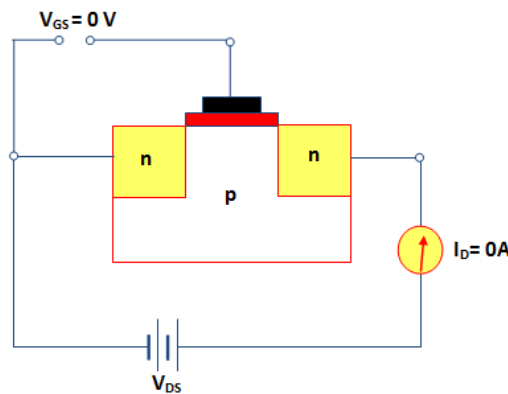

- (i) **When $V_{GS} = 0V$,** there is no channel connecting source and drain. The p-substrate has only a few thermally produced free electrons (minority carriers) so that drain current is almost zero. For this reason, E-MOSFET is normally OFF when $V_{GS} = 0V$.
- (ii) **When V_{GS} is positive,** i.e gate is made positive, it attracts free electrons into the p region. The free electrons combine with the holes next to the SiO_2 layer.

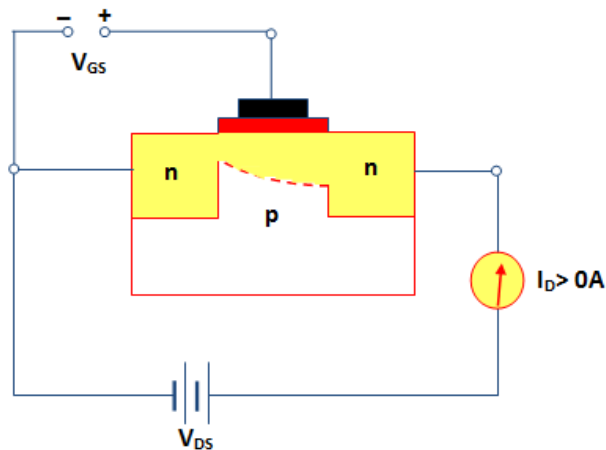

If V_{GS} is positive enough, all the holes touching the SiO_2 layer are filled and free electrons begin to flow from the source to drain. The effect is same as creating a thin layer of n-type material i.e. inducing a thin n-layer adjacent to the SiO_2 layer. Thus the E-MOSFET is turned ON and drain current I_D starts flowing from the source to the drain.

The minimum value of V_{GS} that turns the E-MOSFET ON is called threshold voltage [$V_{GS(th)}$].

(iii) **When V_{GS} is less than $V_{GS(th)}$** , there is no induced channel and the drain current I_D is zero. When V_{GS} is equal to $V_{GS(th)}$, the E-MOSFET is turned ON and the induced channel conducts drain current from the source to the drain.

Beyond $V_{GS(th)}$, if the value of V_{GS} is increased, the newly formed channel becomes wider, causing to I_D to increase.

If the value of V_{GS} decreases not less than $V_{GS(th)}$, the channel becomes narrower and I_D will decrease.

Enhancement-mode N-Channel MOSFET characteristics

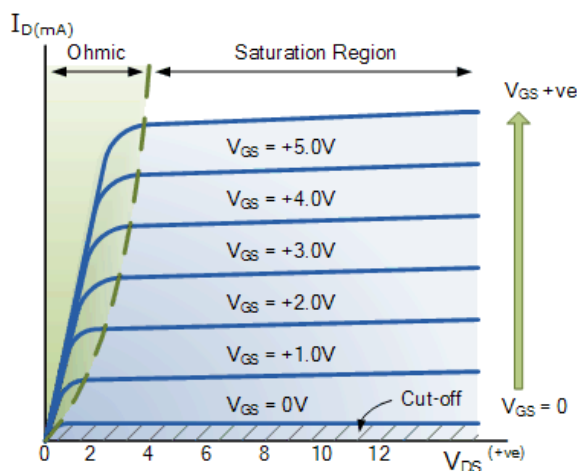

Depletion type MOSFET: The depletion type MOSFET is also further classified into two types, they are n-channel and p-channel and symbols are shown in below

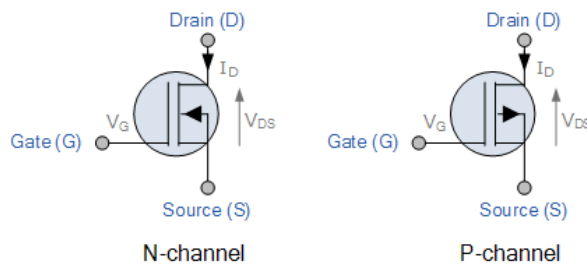

Operation: In a depletion type or DE-MOSFET, a channel for conduction is already constructed physically. Due to this, current flows in between the source and drain without any gate bias voltage. This means that the channel conducts even when $V_{GS} = 0$. The fig.3.17 shown below will help you to understand DE-MOSFET in a better way:

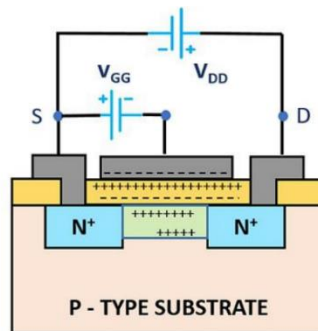
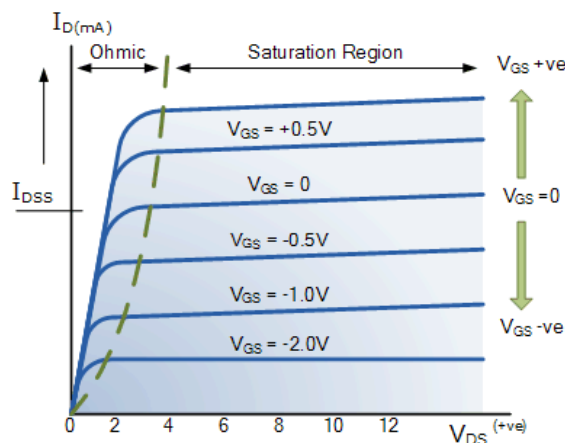

Fig.3.17 N-Channel DE-MOSFET

DE-MOSFET can be operated with both positive and negative gate potential. When the MOSFET is operated with 0 gate voltage it is said that the MOSFET is operating in E-mode. In a DE-MOSFET when the gate potential is made negative with respect to the substrate, it causes repulsion of negative charge carriers out of the initially formed channel. This increases the channel resistance which resultantly reduces the drain current.

Depletion mode N-Channel MOSFET characteristics:



MOSFET Applications

- MOSFETs are used in digital integrated circuits, such as microprocessors.
- Used in memories and in logic CMOS gates.

- Used as analog switches.
- Used as amplifiers.
- Used in the applications of power electronics and switch mode power supplies.
- MOSFETs are used as oscillators in radio systems.
- Used in automobile sound systems and in sound reinforcement systems.

MOSFET as a Switch:

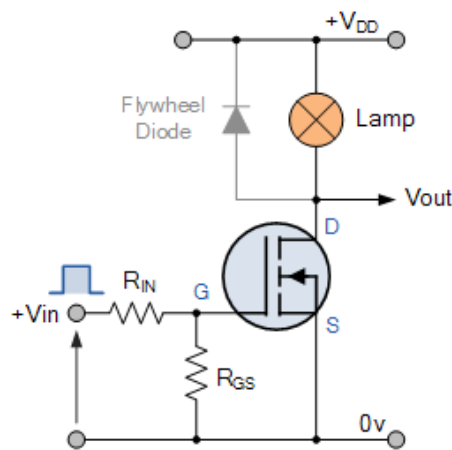

Fig.3.18 MOSFET SWITCH

In Fig. 3.18 enhanced mode and N-channel MOSFET is being used to switch a sample lamp ON and OFF. The positive gate voltage ($V_{GS} = +ve$) is applied to the gate of the MOSFET and the lamp is ON. If zero voltage ($V_{GS} = 0$), applied to the gate of the MOSFET then lamp turns off.

Comparison between BJT, FET and MOSFET

TERMS	BJT	FET	MOSFET
Device type	Current controlled	Voltage controlled	Voltage Controlled
Current flow	Bipolar	Unipolar	Unipolar
Terminals	Not interchangeable	Interchangeable	Interchangeable
Operational modes	No modes	Depletion mode only	Both Enhancement and Depletion modes
Input impedance	Low	High	Very high
Output resistance	Moderate	Moderate	Low
Operational speed	Low	Moderate	High
Noise	High	Low	Low
Thermal stability	Low	Better	High

3.3.4 THYRISTORS

Thyristors are basically classified into three types

- Silicon Controlled Rectifiers (SCRs)
- DIAC (Diodes as AC Switch)
- TRIAC (Triode as AC Switch)

Silicon Controlled Rectifiers (SCRs):

The SCR is a four-layered, three terminal semiconductor device, with each layer consisting of alternately N and P-type materials. The main terminals, labelled anode and cathode, and the control terminal, called the gate, is attached to p-type material near the cathode. These simply named as thyristors.

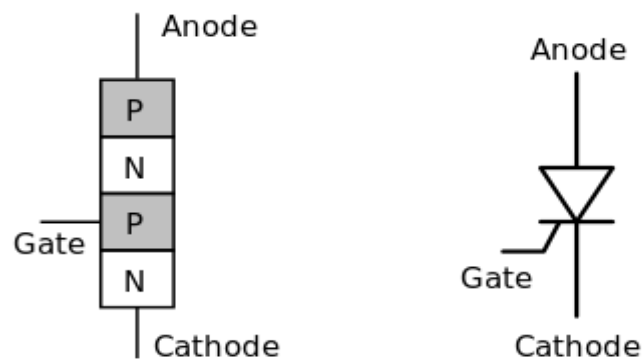

Thyristor structure

Thyristor circuit symbol

The SCR has three p-n junctions (serially named J₁, J₂ and J₃ from the anode).

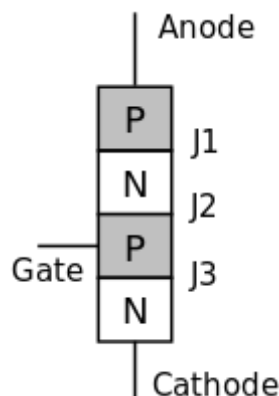

When the anode is at a positive potential V_{AK} with respect to the cathode with no voltage applied at the gate, junctions J₁ and J₃ are forward biased, while junction J₂ is reverse biased. As J₂ is reverse biased, no conduction takes place (Off state). Now if V_{AK} is increased beyond the breakdown voltage V_{BO} of the thyristor, avalanche breakdown of J₂ takes place and the thyristor starts conducting (On state).

If a positive potential V_G is applied at the gate terminal with respect to the cathode, the breakdown of the junction J_2 occurs at a lower value of V_{AK} . By selecting an appropriate value of V_G , the thyristor can be switched into the on state quickly.

Once avalanche breakdown has occurred, the thyristor continues to conduct, irrespective of the gate voltage, until: (a) the potential V_{AK} is removed or (b) the current through the device (anode–cathode) is less than the holding current specified by the manufacturer. Hence V_G can be a voltage pulse.

Switching characteristics

In a conventional thyristor, once it has been switched on by the gate terminal, the device remains latched in the on-state (i.e. does not need a continuous supply of gate current to remain in the on state), providing the anode current has exceeded the latching current (I_L). As long as the anode remains positively biased, it cannot be switched off until the anode current falls below the holding current (I_H).

A thyristor can be switched off if the external circuit causes the anode to become negatively biased. Fig. 3.19 VI characteristics of SCR

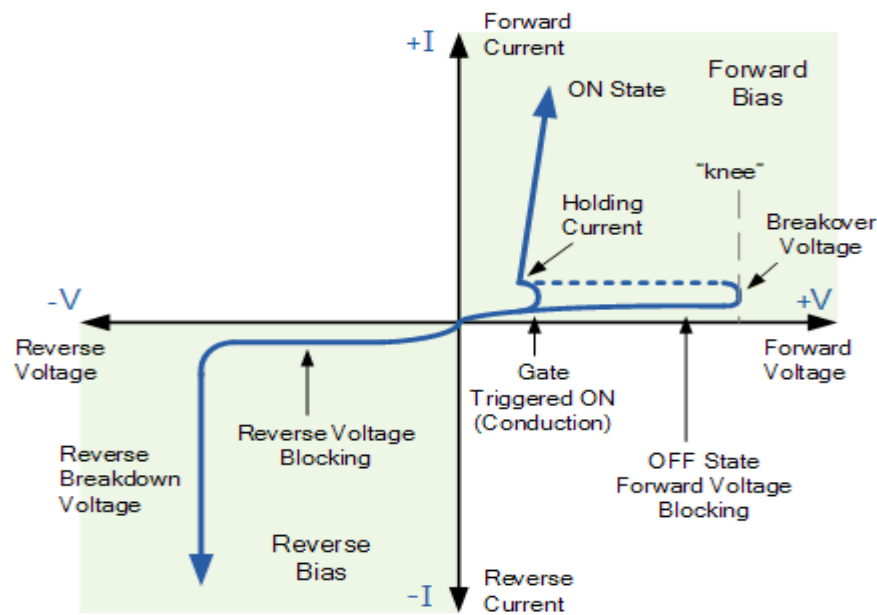

Fig. 3.19 VI characteristics of SCR

Applications

Thyristors are semiconductor devices that are specifically designed for use in high-power switching applications. Thyristors can operate only in the switching mode, where they act like either an open or closed switch and once triggered it will remain conducting. Therefore, in DC circuits and some highly inductive AC circuits the current has to be artificially reduced by a separate switch or turn off circuit.

3.3.5 TRIAC

TRIAC, from triode for alternating current, is a generic trademark for a three terminal electronic component that conducts current in either direction when triggered. It's also called as bidirectional triode thyristor or bilateral triode thyristor. The figure shows the circuit symbol for a TRIAC where A1 is Anode 1, A2 is Anode 2, and G is Gate. Anode 1 and Anode 2 are normally termed Main Terminal 1 (MT1) and Main Terminal 2 (MT2) respectively.

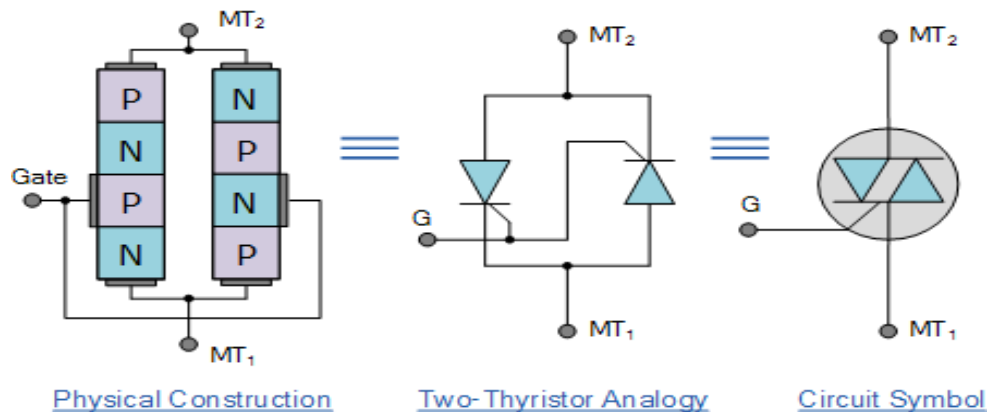

TRIACs are a subset of thyristors. TRIACs differ from SCRs in that they allow current flow in both directions, whereas an SCR can only conduct current in a single direction. Most TRIACs can be triggered by applying either a positive or negative voltage to the gate (an SCR requires a positive voltage). Once triggered, SCRs and TRIACs continue to conduct, even if the gate current ceases, until the main current drops below a certain level called the holding current.

TRIAC's bidirectionality makes them convenient switches for alternating-current (AC). This is commonly used for controlling the speed of induction motors, dimming lamps, and controlling electric heaters.

Triac Characteristics:

Typical V-I characteristics of a TRIAC are shown in figure 3.20. The TRIAC has on and off state characteristics like SCR but now the characteristic is applicable to both positive and negative voltages. This is expected because TRIAC consists of two SCRs connected in parallel but opposite in directions.

TRIAC Applications:

The TRIAC is most commonly used semiconductor device for switching and power control of AC systems as the TRIAC can be switched "ON" by either a positive or negative Gate pulse, regardless of the polarity of the AC supply at that time. This makes the TRIAC ideal to control a lamp or AC motor load with a very basic TRIAC switching circuit.

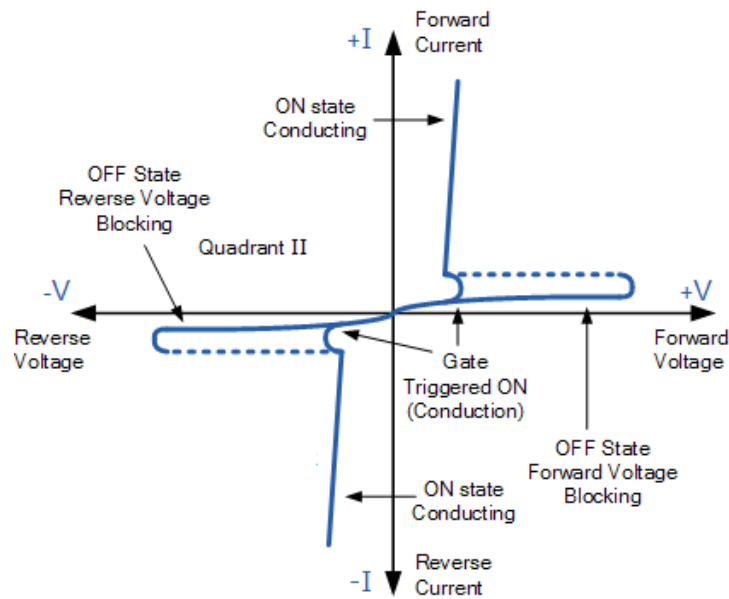

Fig. 3.20 VI Characteristics of TRIAC

3.4 Motors

A motor is an electrical machine which converts electrical energy into mechanical energy. Electrical motors are frequently used as final controlling element in position and speed control systems. Basically, it consists of two parts

- Stator
- Rotor

Classification of Motors:

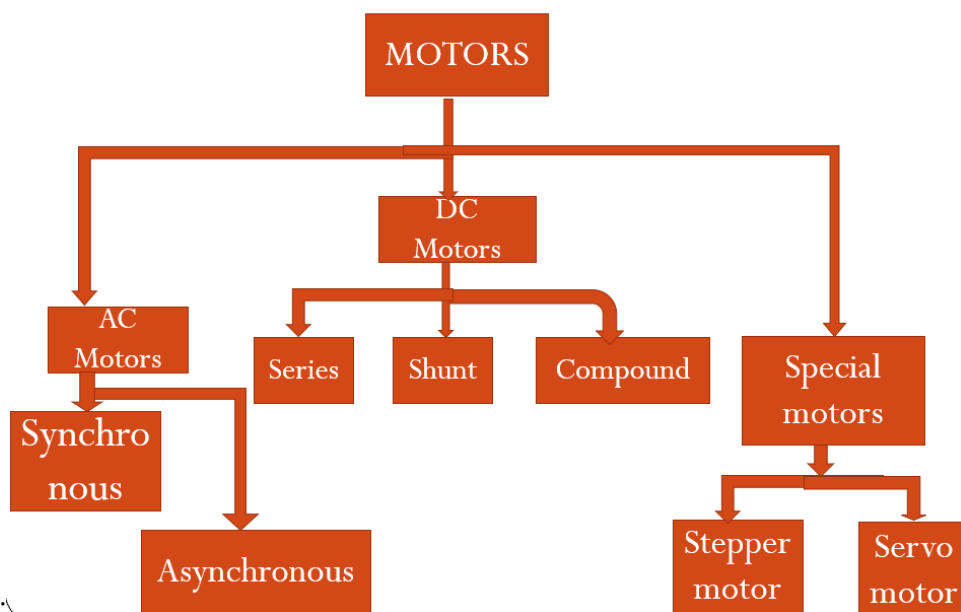

3.4.1 DC Motors:

Construction

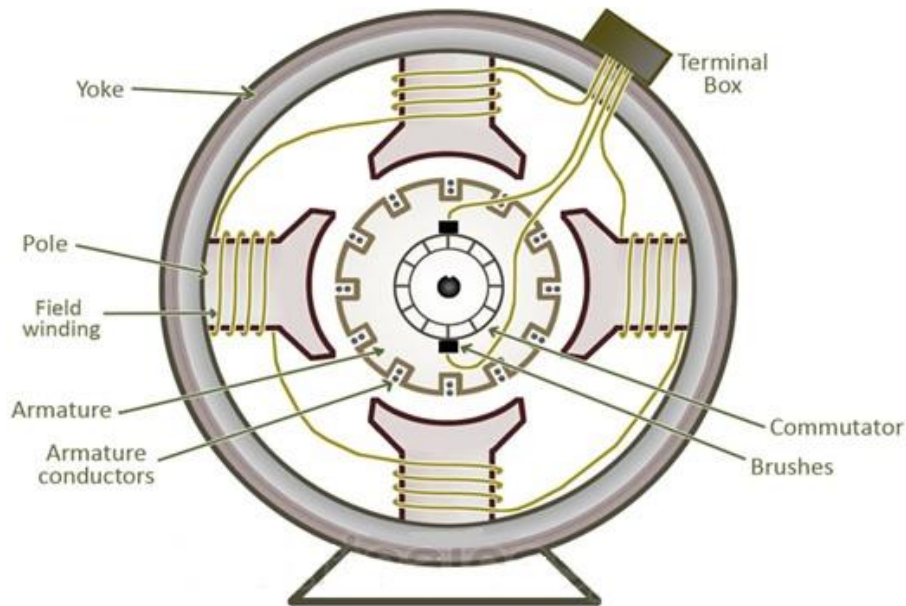

Fig. 3.21 Construction of DC Motor

Working principle of a DC motor:

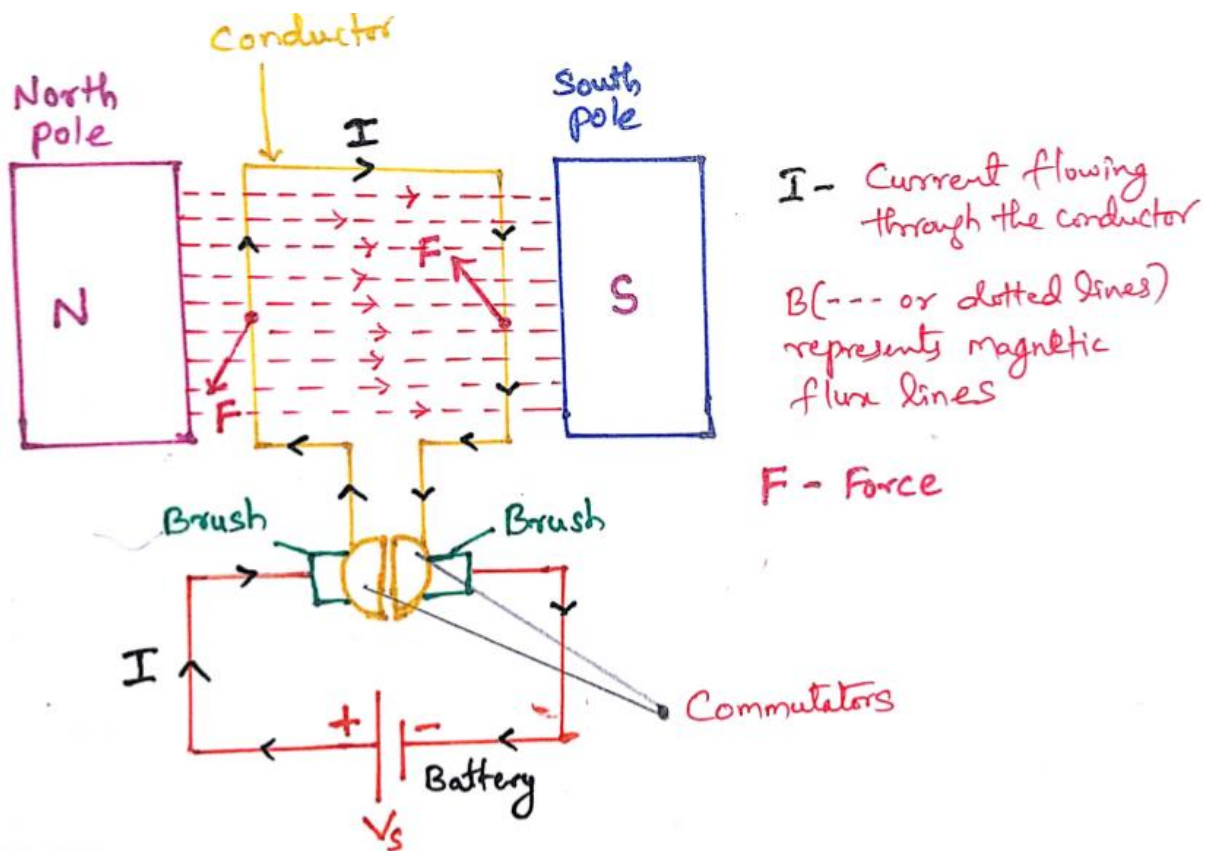

Figure 3.22 Working of DC Motor

"Whenever a current carrying conductor is placed in a magnetic field, it experiences a mechanical force". The direction of this force is given by Fleming's left-hand rule and its magnitude is given by

$$F = BIL$$

Where, B = magnetic flux density,

I = current and

L = length of the conductor.

Same magnitude and opposite forces acting on left and right conductors causes torque ($T = F \times r$) is produced at circumference of the conductors. Because of this twisting force motor starts rotating in anticlockwise direction as shown in above figure 2.

The direction of motor can be controlled by simply changing the supply terminals or interchanging of south and north poles.

Back EMF:

Once motor starts rotating, the conductors cut the magnetic flux lines causing an emf is induced in the armature conductors according to the Faraday's law of electromagnetic induction and is given by

$$E_b = \frac{NP\Phi Z}{60A}$$

Where N- speed of armature

P- number of poles

Φ - magnetic flux lines

A- number of parallel paths

Z- number of conductors

The induced emf opposes the change causing it, according to Lenz's Law. Here it opposes the supply voltage, hence it is called "Back emf".

Significance of Back EMF: Back EMF regulates flow of armature current to meet the load requirements. Hence dc motor acting as self-regulating machine.

Magnitude of back emf is directly proportional to speed of the motor. Consider the load on a dc motor is suddenly reduced. In this case, required torque will be small as compared to the current torque. Speed of the motor will start increasing due to the excess torque. Hence, being proportional to the speed, magnitude of the back emf will also increase. With increasing back emf armature current will start decreasing. Torque being proportional to the armature current, it will also decrease until it becomes sufficient for the load. Thus, speed of the motor will regulate.

On the other hand, if a dc motor is suddenly loaded, the load will cause decrease in the speed. Due to decrease in speed, back emf will also decrease allowing more armature current. Increased armature current will increase the torque to satisfy the load requirement. Hence, presence of the **back emf makes a dc motor 'self-regulating'**.

Types of DC Motors

DC motors are usually classified on the basis of their excitation configuration, as follows -

- Separately excited (field winding is fed by external source)
- Self-excited -
 - Series wound (field winding is connected in series with the armature)
 - Shunt wound (field winding is connected in parallel with the armature)
 - Compound wound -

Separately excited motor:

The separately excited motor has separate control of the armature and field currents.

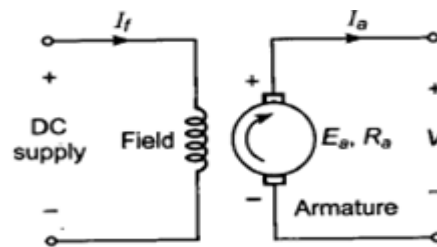

Series-wound:

With the series-wound motor the armature and field coils are in series. Such a motor exerts the highest starting torque and has the greatest no-load speed. Reversing the polarity of the supply to the coils has no effect on the direction of rotation of the motor since both the field and armature currents have been reversed.

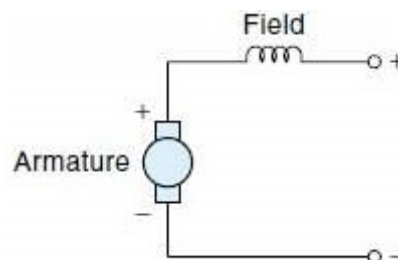

Shunt-wound:

With the shunt-wound motor the armature and field coils are in parallel. It provides lowest starting torque. It provides constant speed regardless of load. To reverse the direction of rotation either armature or field supply must be reversed.

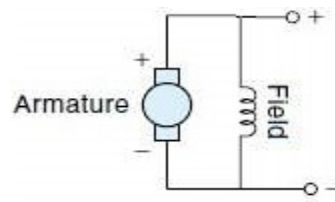
**Compound-wound:**

The compound motor has two field windings, one in series with the armature and one in parallel. The aim is to get the best features of the series and shunt-wound motors, such as high starting torque and good speed regulation.

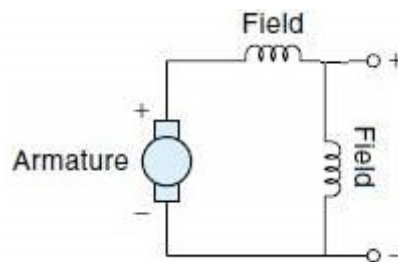
**3.4.2 AC MOTORS****3-Ø Induction Motor:**

The main body of the Induction Motor comprises of two major parts:

1. Stator
2. Rotor

Stator: The stator of an induction motor is in principle, the same as that of a synchronous motor (or) generator. It is made up of a number of stampings, which are slotted to receive the windings. The stator carries a 3-phase winding and is fed from a 3-phase supply. It is wound for a definite number of poles; the exact number of poles being determined by the requirements of speed. The number of poles is higher, lesser the speed and vice-versa. The stator winding, when supplied with a 3-phase currents, produce a magnetic flux, which is of constant magnitude but which revolves at synchronous speed and is given by

$$N_s = 120 \times f / p$$

Where N_s = synchronous speed

f = Frequency

p = no. of poles

This revolving magnetic flux induces emf in rotor by mutual induction.. Figure 3.23 shows construction of stator.

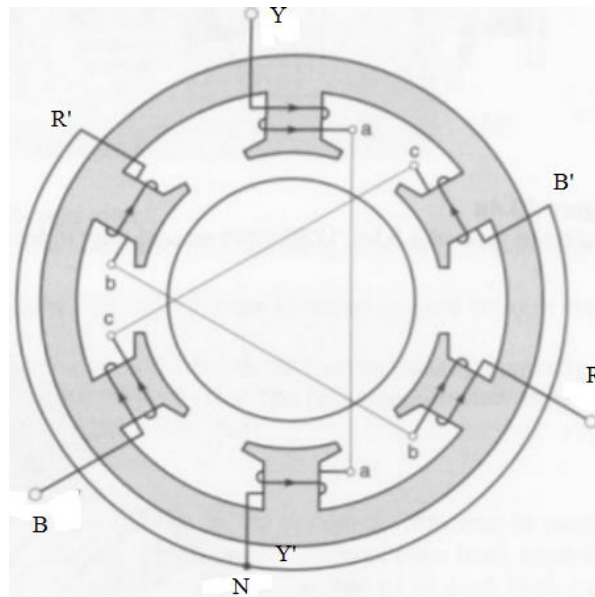

Fig.3.23 Construction of Stator

Rotor: two types of constructions are commonly used

- (i) Squirrel cage Rotor:
- (ii) Phase wound (or) slip-ring Rotor:

Squirrel cage Rotor:

Almost 90 percentage of induction motors are squirrel-cage type, because this type of rotor has the simplest and most rugged construction imaginable and is almost indestructible. The Rotor consists of cylindrical laminated core with parallel slots for carrying the rotor conductors which, it should be noted clearly, are not wires but consists of heavy bars of copper, aluminium or alloys. One bar is placed in each slot; rather the bars are inserted from the end when semi-enclosed slots are used. The rotor bars are brazed or electrically welded or bolted to two heavy and stout short circuiting end-rings, thus giving us, what is called a squirrel cage construction and is shown in figure 3.24.

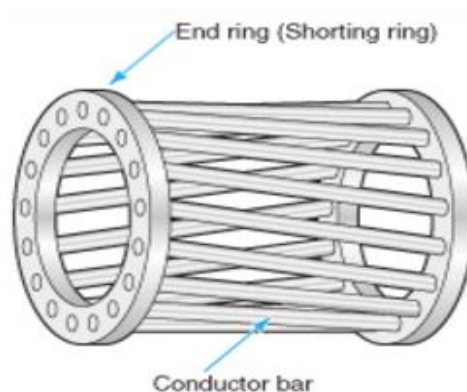

Fig.3.24 Squirrel cage rotor

Principle and working:

Induction motor works on the principle of electromagnetic induction. When three phase supply is given to the stator winding, a rotating magnetic field of constant magnetic field is produced. The speed of rotating magnetic field is synchronous speed, N_s in r.p.m.

$$N_s = 120 \times f / p$$

Where N_s = synchronous speed

f = Frequency

p = no. of poles

Now at this instant rotor is stationary and stator flux R.M.F. is rotating. So its obvious that there exists a relative motion between the R.M.F. and rotor conductors. Now the R.M.F. gets cut by rotor conductors as R.M.F. sweeps over rotor conductors. Whenever a conductor cuts the flux, emf gets induced in it. So emf gets induced in the rotor conductors called rotor induced emf. This is electromagnetic induction. As rotor forms closed circuit, induced emf circulates current through rotor called rotor current.

Any current carrying conductor produces its own flux. So rotor produces its flux called rotor flux. For assumed direction of rotor current, the direction of rotor flux is clockwise/anticlockwise.

The direction can be easily determined using right hand thumb rule. Now there are two fluxes, one R.M.F. and another rotor flux. Both the fluxes interact with each. On left of rotor conductor, two fluxes are in same direction hence added up to get high flux area. On right side of rotor conductor, two fluxes are in opposite direction hence they cancel each other to produce low flux area. So rotor conductor experiences a force from left to right, due to interaction of the two fluxes. As all rotor conductor experiences a force, overall rotor experiences a torque and starts rotating.

After rotor starts rotating it try to catch-up synchronous speed. Once rotor speed N_r reaches synchronous speed N_s . The relative motion between R.M.F and rotor is zero. Hence the rotor always slips by a synchronous speed.

$$\% \text{Slip} = \frac{N_s - N_r}{N_s} \times 100$$

3.4.3 STEPPER MOTOR

A stepper motor is an electromechanical device which converts electrical pulses into discrete mechanical movements. The sequence of the applied pulses is directly related to the direction of motor shafts rotation. The speed of the motor shafts rotation is directly related to the frequency of the input pulses.

STEPPER MOTOR WORKING

Stepper motors work on the principle of electromagnetism. There is a soft iron or magnetic rotor shaft surrounded by the electromagnetic stators. The rotor and stator have poles which may be teathed or not depending upon the type of stepper. When the stators are energized the rotor moves.

TYPES OF STEPPER MOTOR:

By construction the step motors come into three broad classes:

- Permanent Magnet Stepper
- Variable Reluctance Stepper
- Hybrid Step Motor

PERMANENT MAGNET STEPPER:

- The rotor and stator poles are not teathed.
- The rotor has alternative north and south poles parallel to the axis of the rotor shaft.
- When a stator is energized, it develops electromagnetic poles.
- The magnetic rotor aligns along the magnetic field of the stator.

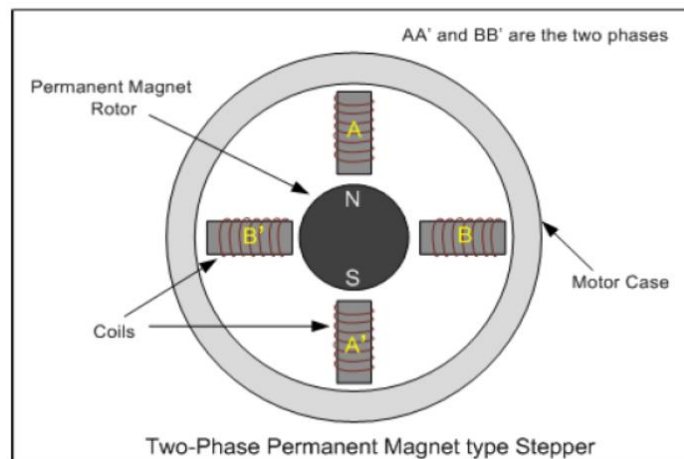

Operation:

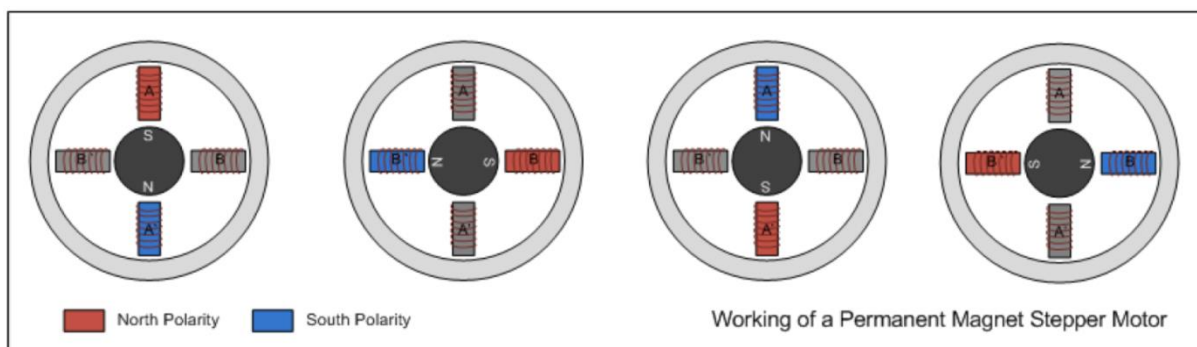

VARIABLE RELUCTANCE STEPPER:

It has a toothed non-magnetic soft iron rotor. When the stator coil is energized the rotor moves to have a minimum gap between the stator and its teeth.

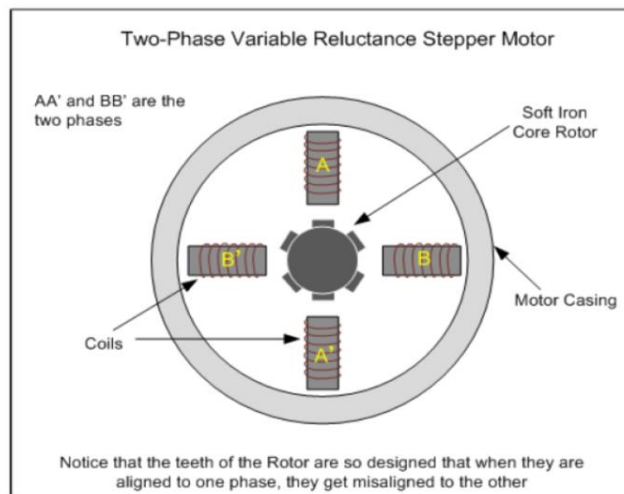

Operation:

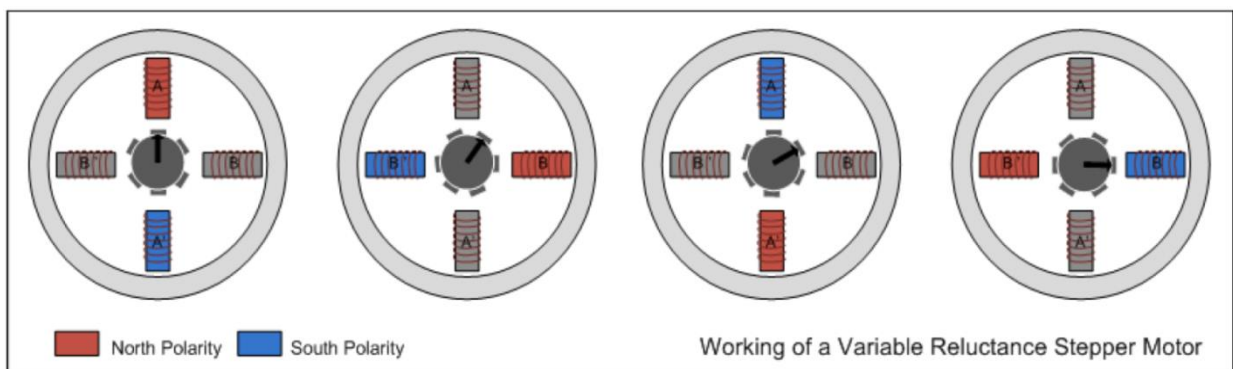

HYBRID STEPPER:

A hybrid stepper is a combination of both permanent magnet and the variable reluctance. It has a magnetic teathed rotor which better guides magnetic flux to preferred location in the air gap.

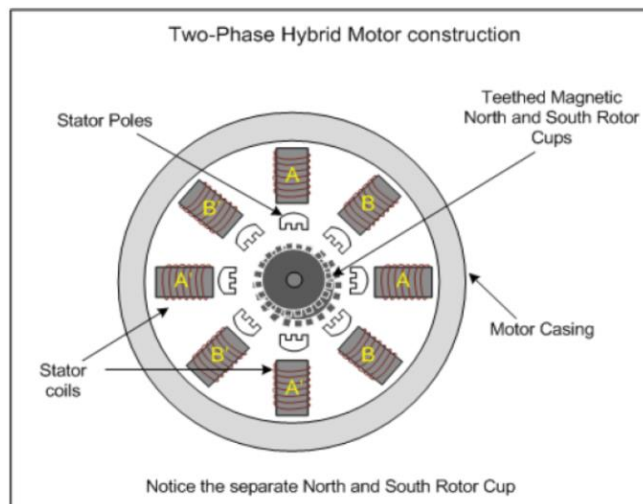

Operation:

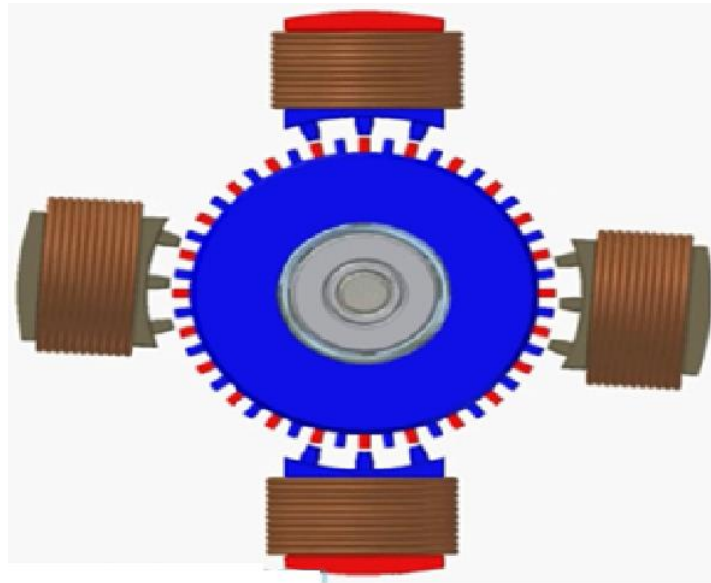

If pulse is given to windings of stator, then the rotor teeth are aligned with stator teeth as shown in above figure.

TYPES OF WINDING AND LEAD LEAD-OUT:

Based on winding arrangement stepper motors are classified into two types.

1. Uni polar Stepper motor
2. Bipolar stepper motor

In unipolar stepper motor pole may have one lead common i.e., center tapped. In bipolar stepper motor there is a single winding per phase. The direction of current needed to be changed by the driving circuit so that the driving circuit of the stepper motor becomes complex.

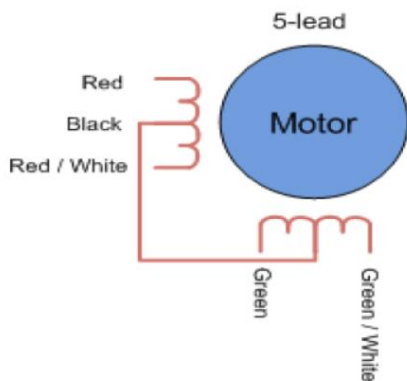

Fig. 3.25 (a) Unipolar

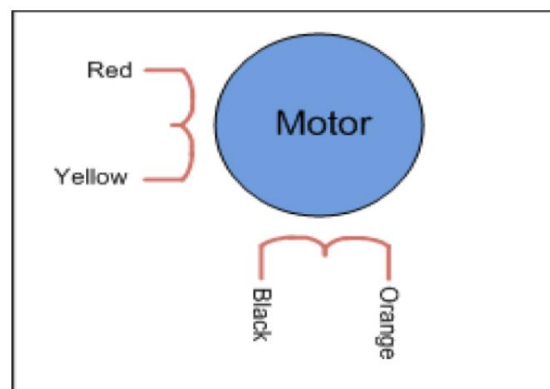

Fig. 3.25(b) bipolar

3.5 MECHANICAL ACTUATORS

3.5.1 GEARS

Gear trains are used to transfer and transform rotational motion. They are used when a change in speed or torque of a rotating device is needed. e.g. the car gear box enables the driver to match the speed and torque requirements of the terrain with the engine power available.

Rotary motion can be transferred from one shaft to another by a pair of rolling cylinders. The transfer of the motion between the two cylinders depends on the frictional forces between the two surfaces in contact. Slip can be prevented by the addition of meshing teeth to the two cylinders also gears can be used to transfer rotating motion for shafts which have axis inclined to one another, i.e. the two shafts intersect (bevel gears)

Slip can be prevented by the addition of meshing teeth to the two cylinders

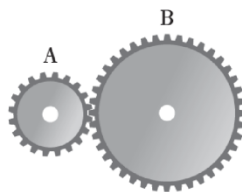

Fig. Two meshed gears

When two gears in mesh the larger gear wheel is called the spur (or crown wheel), the smaller is called the pinion.

Gears basically classified into two types based on their axes and they are shown in fig. 3.26

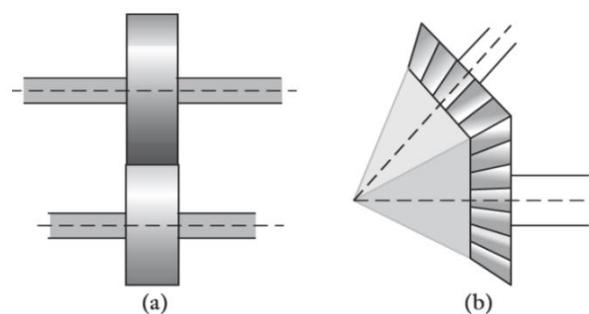

Fig.3.26 (a) Parallel gear axes, (b) axes inclined to one another

Parallel shaft gears: These are further divided into spur, helical, double helical and Rack and pinion are shown in fig. 3.27

Spur gears: have axial teeth with the teeth cut along axial lines parallel to the axis of the shaft

Helical gears: helical teeth with teeth being cut on helix helical gears have the advantage of smoother drive and prolonged life of gears, however, the inclination of the teeth results in an axial force component on the shaft bearing which can be overcome by using double helical teeth.

Rack and pinion: are used to transfer linear to rotary motion

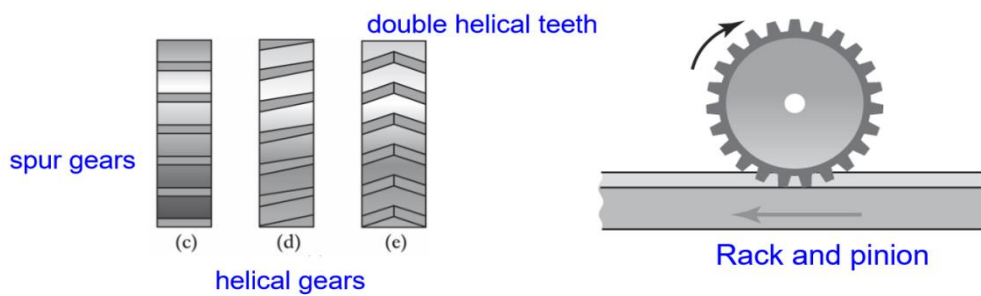

Fig. 3.27 Types of Parallel axes gears

Gear ratio:

Consider meshed wheels A & B. A with 40 teeth and B with 80 teeth.

$$\frac{\omega_A}{\omega_B} = \frac{\text{No of teeth on B}}{\text{No of teeth on A}} = \frac{80}{40} = 2$$

$$\omega_A = 2\omega_B$$

We can also write :

$$\frac{\omega_A}{\omega_B} = \frac{d_B}{d_A} = \text{gear ratio} = 2$$

Wheel B must have twice the diameter of wheel A. Gear ratio is used for the ratio of the angular speeds of a pair of intermeshed gear wheels

Types of gear trains:

Simple gear train: The simple gear train is shown in fig. 3.28 and this term is used for a system where each shaft carries only one gear wheel here we have

$$G = \frac{\omega_A}{\omega_C} = \frac{\omega_A}{\omega_B} \times \frac{\omega_B}{\omega_C}$$

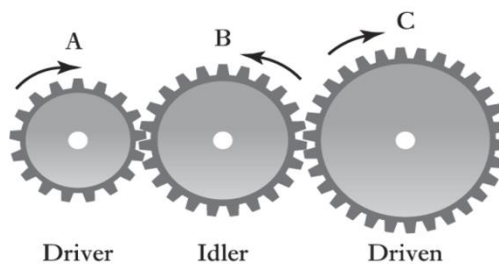

Fig. 3.28 Simple gear train

The intermediate wheel B is termed the idler wheel is used to change the direction of rotation of the output wheel.

The compound gear train: The compound gear train is shown in fig.3.29 and this term is used to describe a gear train when two (or more) wheels are mounted on a common shaft. When two

wheels are mounted on the same shaft, they have the same angular velocity. Thus, for both compound gear trains.

$\omega_B = \omega_C$ The over all gear ratio $G = \frac{\omega_A}{\omega_D} = \frac{\omega_A}{\omega_B} \times \frac{\omega_B}{\omega_C} \times \frac{\omega_C}{\omega_D} = \frac{\omega_A}{\omega_B} \times \frac{\omega_C}{\omega_D}$

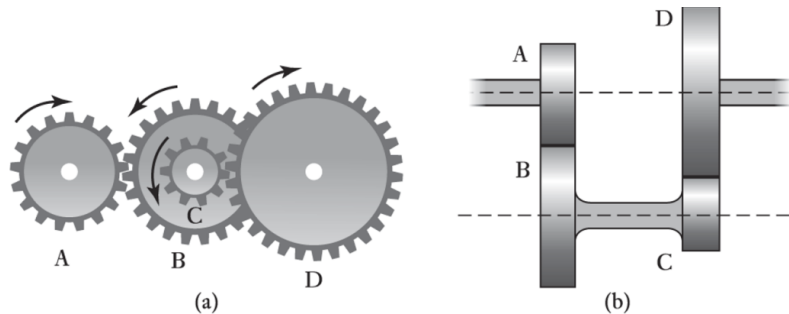
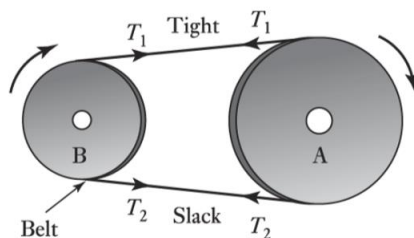

Fig. 3.29 Compound gear trains

3.5.2 BELT & CHAIN DRIVES

Belt Drives is essentially a pair of rolling cylinders with the motion of one cylinder being transferred to the other by a belt. The transmitted torque is due to differences in tension that occur in the belt during operation. This difference results in a tight side and slack side for the belt. If the tension on the tight side is T1 and that on the slack side is T2 then: Torque on A = (T1-T2)rA Torque on B = (T1-T2)rB



rA and rB are the radius of A and B

If belt speed is v then angular speed for A and B are:

$$\omega_A = \frac{v}{r_A} \quad \& \quad \omega_B = \frac{v}{r_B}$$

Power on either pulley is:

$$P = T \cdot \omega$$

$$P = (T1 - T2)v$$

If distances between shafts are large, then a belt drive is more suitable than gears.

Forms of reversing drives: two forms of reversing belt drives are shown in fig. 3.30.

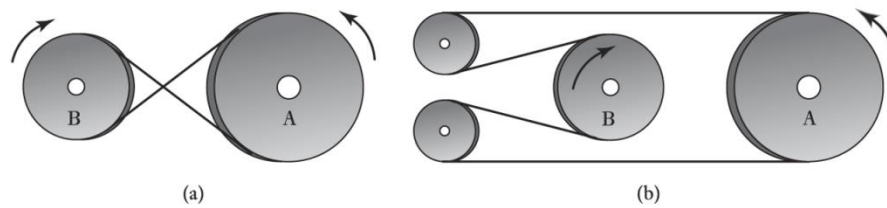

Fig.3.30 Reversed belt drives: (a) crossed belt, (b) open belt

Types of belts: Types of belts are shown in fig.3.31

Flat: Produces little noise, can transmit power over long distance. Crowned pulleys are used to keep the belts from running off the pulleys

Round: Has circular cross section and is used with grooved pulleys

V belts: Used with grooved pulleys, less efficient than flat belts

Timing belts: Required toothed wheels; it can run at slow or fast speed, does not stretch or slip

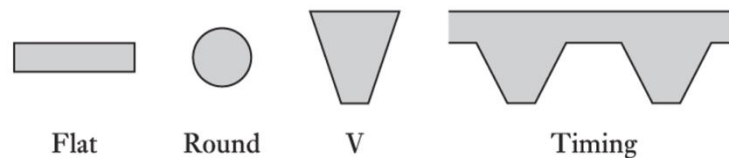

Fig. 3.31 Types of belts

CHAINS

- Slip can be prevented by the use of chains which lock into teeth on the rotating cylinders.
- The drive mechanism used with bicycle is an example of a chain drive.
- It enables a number of shafts to be driven by single wheel and so give a multiple drive

3.5.3 BEARINGS

The main function of a rotating shaft is to transmit power from one end of the line to the other.

- It needs a good support to ensure stability and frictionless rotation.
- The support for the shaft is known as “**bearing**”.
- ✓ The shaft has a “**running fit**” in a bearing. Whenever there is a relative motion of one surface in contact with another either by rotating or sliding, the frictional forces generate heat which waste the energy and results in wear.
- ✓ All bearing is provided some lubrication arrangement to reduced friction between shaft and bearing.

Bearings are machine elements which are used to support a rotating member viz., a shaft. The bearings are classified based on the type of contact they have between the rotating and the stationary member



Sliding contact bearings: Continuous contact between shaft and bearing

- The sliding contact bearings having surface contact shown in below figure

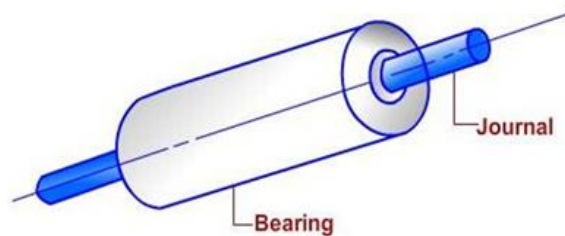

- Sliding contact bearings are classified in three ways.
 1. Based on type of load carried
 2. Based on type of lubrication
 3. Based on lubrication mechanism

Based on type of load carried:

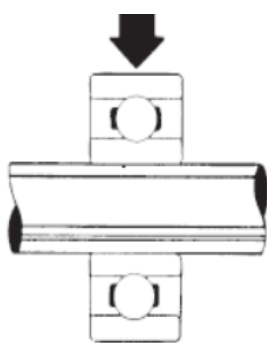

a) Radial bearing

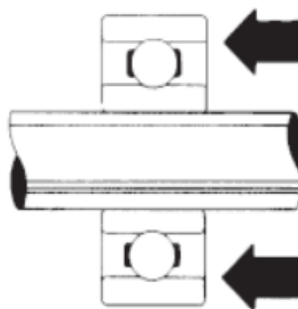

b) Axial bearing

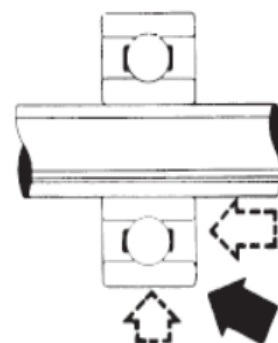

c) Angular bearing

- Radial bearing carries radial load
- Axial bearing carries axial load
- Angular bearing carries both radial and axial loads.

Based on type of lubrication:

- The type of lubrication means the extent to which the contacting surfaces are separated in a shaft bearing combination. This classification includes
 - (a) Thick film lubrication (There is no surface contact)
 - (b) Thin film lubrication (There is a slight surface contact)
 - (c) Boundary lubrication (There is a continuous surface contact)

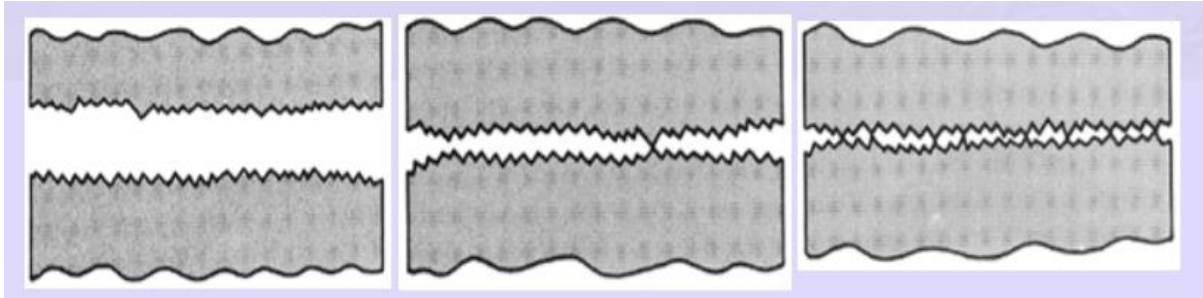

(a) Thick film lubrication (b) Thin film lubrication (c) Boundary lubrication

Based on lubrication mechanism:

- Hydrodynamic lubricated bearings
- Hydrostatic lubricated bearings
- Boundary lubricated bearings
- Solid film lubricated bearings

ROLLING CONTACT BEARINGS

- Rolling contact bearings are also known as anti-friction bearing due to its low friction characteristics between ball and inner and outer rings.
- Rolling contact bearings are used for radial load, thrust load and combination of these both loads.
- Rolling contact bearings are often used due to its lower price, less maintenance cost and easy to operate.

Parts of Rolling contact bearings

- Outer race (also called outer ring or cup)
- Inner race (also called inner ring or cone)
- Rolling elements (either balls or rollers)
- Separator (also called cage or retainer)

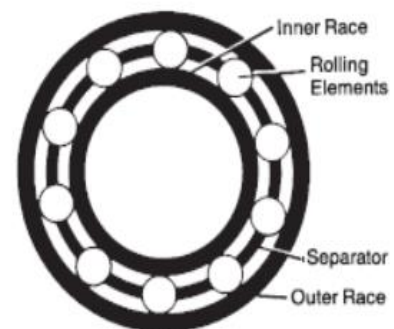

Rolling Contact bearings are of two types they are:

- Ball bearing: Point contact between shaft and bearing.
 - Roller bearing: Line contact between shaft and bearing.

4.1 SIGNAL CONDITIONING

In electronics, signal conditioning means manipulating an analog signal in such a way that it meets the requirements of the next stage for further processing. Most common use is in analog-to-digital converters.

A basic measurement system consists mainly of the three blocks: sensing element, signal conditioning element and signal processing element, as shown in fig.4.1. The sensing element converts the non-electrical signal (e.g. temperature) into electrical signals (e.g. voltage, current, resistance, capacitance etc.). The job of the signal conditioning element is to convert the variation of electrical signal into a voltage level suitable for further processing. The next stage is the signal processing element. It takes the output of the signal conditioning element and converts into a form more suitable for presentation and other uses (display, recording, feedback control etc.).

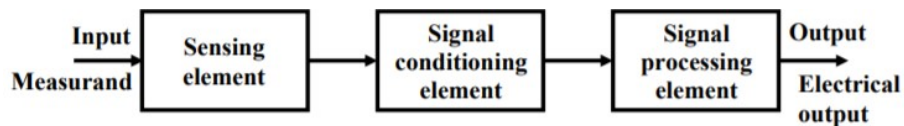

Fig. 4.1 Elements of measuring system

Functions of signal conditioning circuits

- Filtering
- Amplifying
- Electrical Isolation
- Amplification
- Linearization
- Attenuation

4.2 POWER SUPPLY UNIT

In most of our electronic products or projects we need a power supply for converting mains AC voltage to a regulated DC voltage. For making a power supply following components is essential.

1. Transformer
2. Rectifier
3. Filter
4. Regulator

The basic block diagram of power supply unit is shown in fig.4.2.

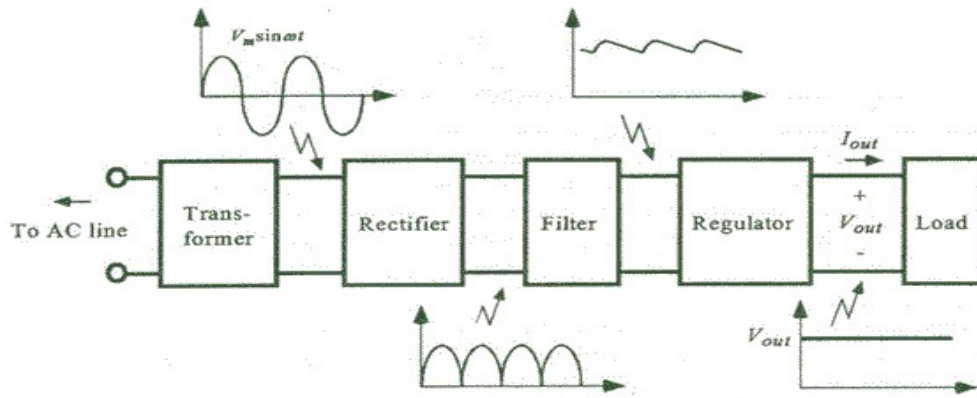

Fig. 4.2 Components of linear power supply

The Transformer:

The transformer takes the AC voltage (230V, 50Hz), and supplies AC voltage at required level. If we want to obtain a final DC voltage of 12 volts, the secondary windings of the transformer must have an AC voltage 16.92V

$$V_p = 12 \times 1.41 = 16.92 \text{ volts.}$$

This can be achieved by selecting transformer turns ratio, and is given by

$$(N_1/N_2) = (V_1/V_2)$$

Where V_1 = transformer primary voltage

V_2 = transformer secondary voltage

N_1 = number of turns of primary

N_2 = number of turns of secondary

The rectifier:

The rectifier transforms the secondary winding AC voltage into a pulsating DC voltage. (look at the diagram. Various forms of rectifier circuit are available.

- Half-wave rectifier
- Full-wave rectifier
- Bridge rectifier

The Filter:

The output of rectifier contains DC component as well as AC component. Filters are used to minimise the undesirable AC. Some Important filters are

- Inductor filter
- Capacitor filter
- LC filter
- CLC filter

The Voltage regulator:

The output voltage of power supply changes whenever the input voltage and load changes. Hence the output of filter is connected to a regulator. A voltage regulator is an electronic circuit that provides stable D voltage independent of load, temperature and AC input variations. The zener diode normally used in voltage regulators. These available in IC forms with different output voltages

78xx series for +ve voltages and 79xx for -ve voltages:

Ex: 7805 is provides constant +5V

7905 is provides constant -5V

Design of 12V DC Power Supply:

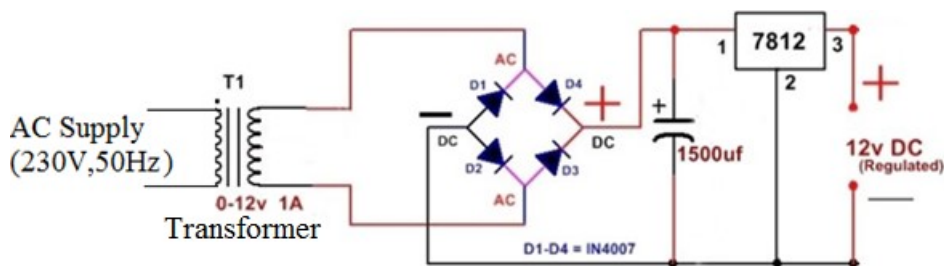

Design of 5V DC Power Supply:

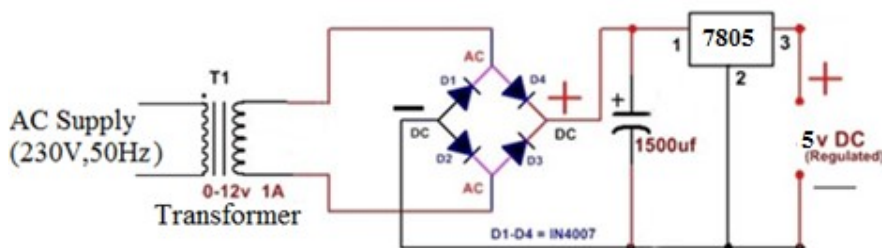

4.3 OPERATIONAL AMPLIFIERS (OP-AMP)

An Operational Amplifier is an integral part of any signal conditioning circuit. Op-Amp is an amplifier which will perform analog mathematical operations. The symbol of Op-Amp is shown in Fig.4.3.

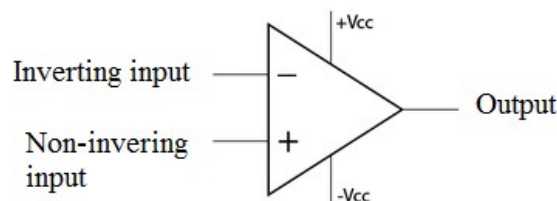

Fig. 4.3 Symbol of Op-Amp

Ideal characteristics of Op-Amp:

- Infinite Open-Loop Gain
- Infinite Input Impedance

- Zero Output Impedance
- Zero Noise Contribution
- Zero output Offset
- Infinite Bandwidth
- Zero drift

Op- amps are available in IC form. The most commonly used op-amp IC is IC 741. It has 8 pins as shown in fig. 4.4

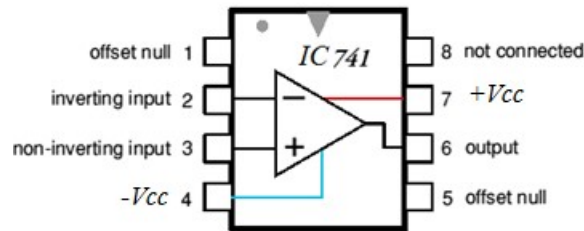

Fig. 4.4 Pin diagram of IC 741.

Operation: Ideally the op-amp amplifies only the difference in voltage between the two inputs, which is called the differential input voltage. The output voltage of the op-amp V_{out} is given by the equation

$$V_{out} = A_{OL} (V_+ - V_-)$$

where A_{OL} is the open-loop gain of the amplifier (the term "open-loop" refers to the absence of a feedback loop from the output to the input).

V_+ = voltage at non-inverting terminal

V_- = voltage at inverting terminal

Open loop configuration of Op-Amp:

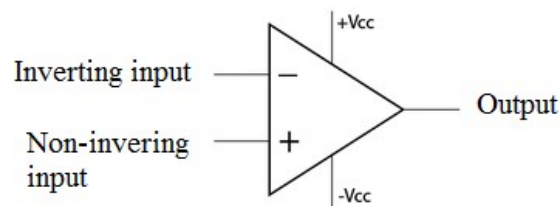

The magnitude of A_{OL} is typically very large (100,000 or more for integrated circuit op-amps), and therefore even a quite small difference between V_+ and V_- drives the amplifier output nearly to the supply voltage. Situations in which the output voltage is equal to or greater than the supply voltage are referred to as *saturation* of the amplifier. This configuration is used for realization of Comparator and Analog to digital converters.

4.3.1 Op-Amp as a Comparator

With reference to the op-amp comparator circuit as shown in fig. 4.5, let's first assume that V_{IN} is less than the DC voltage level at V_{REF} , ($V_{IN} < V_{REF}$). As the non-inverting

(positive) input of the comparator is less than the inverting (negative) input, the output will be LOW and at the negative supply voltage, $-V_{CC}$ resulting in a negative saturation of the output.

If we now increase the input voltage, V_{IN} so that its value is greater than the reference voltage V_{REF} on the inverting input, the output voltage rapidly switches HIGH towards the positive supply voltage, $+V_{CC}$ resulting in a positive saturation of the output.

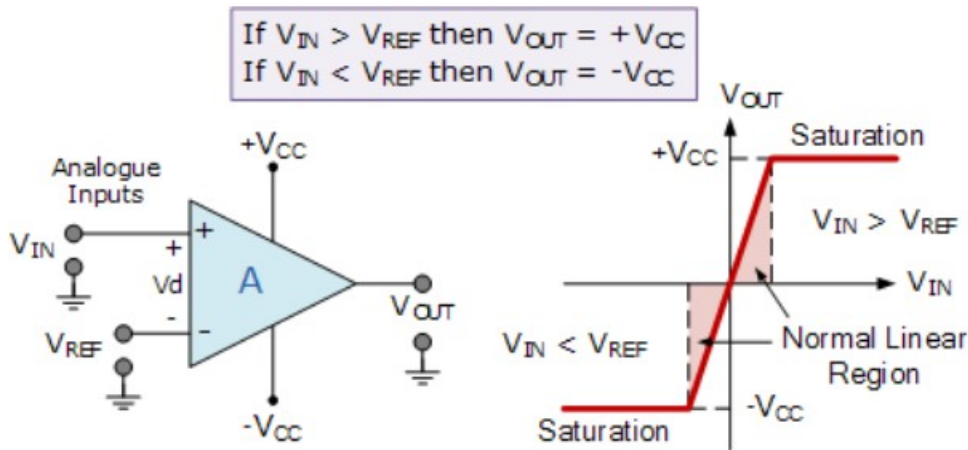
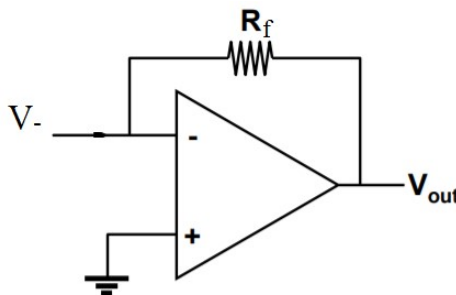

Fig. 4.5 Op-Amp as a comparator

Closed loop configuration of Op-Amp: If predictable operation is desired, negative feedback is used, by applying a portion of the output voltage to the inverting input.



This configuration is used for realization of several mathematical operations like addition, subtraction, integration, differentiation etc.,

4.3.2 Inverting Amplifier

The output of inverting amplifier is 180° out of phase with respect to input. The circuit diagram of inverting amplifier is shown in fig. 4.6.

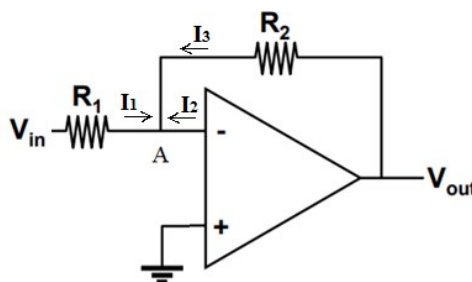

Fig. 4.6 Inverting Amplifier

Due to virtual ground the voltage at inverting terminal is zero i.e. $V_A=0$. Virtual ground is a node (node A) which is not physically connected to ground but it behaves like a ground.

Apply KCL at node A

$$I_1+I_2+I_3=0 \quad (1)$$

We know that No Current Flows into the Input Terminals

Hence $I_2=0$

Then eq (1) becomes

$$I_1 + I_3=0 \quad (2)$$

From ohms law

$$\frac{V_{in}-V_A}{R_1} + \frac{V_{out}-V_A}{R_2} = 0 \quad (3)$$

Substituting $V_A=0$, the eq(3) becomes

$$\frac{V_{in}}{R_1} + \frac{V_{out}}{R_2} = 0 \quad (4)$$

By simplifying eq(4) we get output voltage of Inverting Amplifier

$$V_{out} = -\left(\frac{R_2}{R_1}\right)V_{in}$$

Then, the Closed-Loop Voltage Gain of an Inverting Amplifier is given as.

$$A_{CL} = \frac{V_{out}}{V_{in}} = -\left(\frac{R_2}{R_1}\right)$$

4.3.3 Non-Inverting Amplifier

The output of non-inverting amplifier is in of phase with respect to input. The circuit diagram of non- inverting amplifier is shown in fig. 4.7.

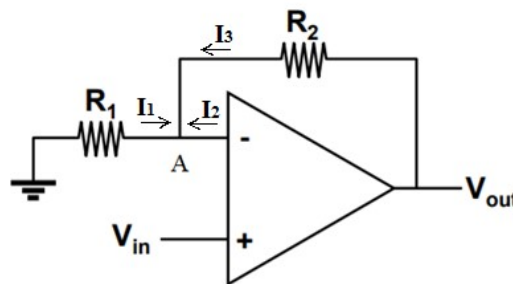

Fig. 4.7 Non-inverting amplifier

Due to virtual ground the voltage at inverting terminal is zero i.e. $V_A=V_{in}$.

Apply KCL at node A

$$I_1+I_2+I_3=0 \quad (1)$$

We know that No Current Flows into the Input Terminals

Hence $I_2=0$

Then eq(1) becomes

$$I_1 + I_3 = 0 \quad (2)$$

From ohms law

$$\frac{0 - V_A}{R_1} + \frac{V_{out} - V_A}{R_2} = 0 \quad (3)$$

Substituting $V_A = V_{in}$, the eq(3) becomes

$$\frac{V_{in}}{R_1} + \frac{V_{out} - V_{in}}{R_2} = 0 \quad (4)$$

By simplifying eq(4) we get output voltage of non-inverting Amplifier

$$V_{out} = \left(1 + \frac{R_2}{R_1}\right) V_{in}$$

Then, the Closed-Loop Voltage Gain of non-inverting Amplifier is given as.

$$A_{CL} = \frac{V_{out}}{V_{in}} = \left(1 + \frac{R_2}{R_1}\right)$$

4.3.4 Summing Amplifier

Summing amplifier amplifies sum of all inputs. The circuit diagram of Summing amplifier is shown in fig. 4.8.

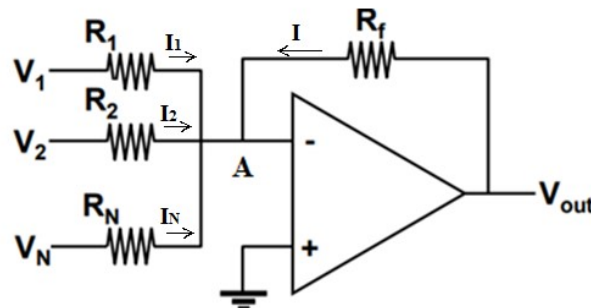

Fig. 4.8. Summing amplifier

Apply KCL at node A

$$I = - (I_1 + I_2 + \dots + I_N) \quad (1)$$

$$\frac{V_{out} - V_A}{R_f} = - \left(\frac{V_1 - V_A}{R_1} + \frac{V_2 - V_A}{R_1} + \dots + \frac{V_N - V_A}{R_N} \right) \quad (2)$$

Substituting $V_A = 0$, and assuming $R_1 = R_2 = \dots = R_N = R$, the eq(2) becomes

$$V_{out} = - \frac{R_f}{R} (V_1 + V_2 + \dots + V_N)$$

4.3.5 Difference Amplifier

The circuit diagram of difference amplifier is shown in fig. 4.9.

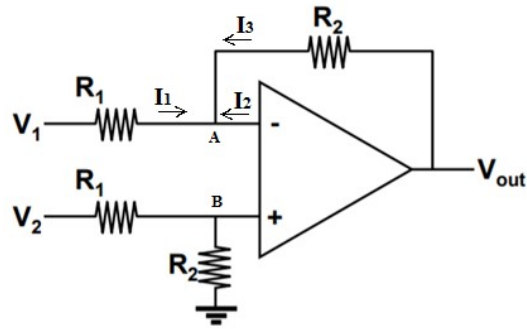

Fig. 4.9. Difference amplifier

It amplifies difference of two input signals under closed loop condition. It combination of inverting and non-inverting amplifiers. Hence the output voltage is combination of non-inverting and inverting amplifier outputs. The output voltage is given by

$$V_{out} = (V_{01} + V_{02}) \quad (1)$$

Where

V_{01} = Inverting amplifier output voltage

V_{02} = Non-inverting amplifier output voltage

For deriving V_{01} assume that $V_2 = 0$, then the voltage at Node B=0. From virtual ground, the voltage at Node A is also zero ($V_A=0$)

$$V_{01} = -\frac{R_2}{R_1}(V_1) \quad (2)$$

For deriving V_{02} assume that $V_1=0$, then the voltage at Node B is given by

$$V_B = \frac{R_2}{R_1+R_2}(V_2) \quad (3)$$

From virtual ground, $V_A=V_B$

Apply KCL at node A

$$I_1+I_2+I_3=0 \quad (4)$$

We know that op-amp input terminals will not draw any current.

Hence $I_2=0$

Then eq(4) becomes

$$I_1 + I_3=0 \quad (5)$$

$$\frac{V_1-V_B}{R_1} + \frac{V_{02}-V_B}{R_2} = 0 \quad (6)$$

Substituting $V_1=0$, V_{02} becomes

$$\frac{0 - V_B}{R_1} + \frac{V_{02} - V_B}{R_2} = 0$$

$$V_{02} = \left(1 + \frac{R_2}{R_1}\right)V_B \quad (7)$$

Substitute V_B in eq(7)

$$V_{o2} = \left(1 + \frac{R_2}{R_1}\right) \frac{R_2}{R_1 + R_2} (V_2)$$

$$V_{o2} = \left(\frac{R_1 + R_2}{R_1}\right) \frac{R_2}{R_1 + R_2} (V_2)$$

$$V_{o2} = \frac{R_2}{R_1} (V_2) \quad (8)$$

Substitute V_{01} and V_{02} in eq (1)

$$V_{out} = (V_{01} + V_{02}) = -\frac{R_2}{R_1} (V_1) + \frac{R_2}{R_1} (V_2)$$

$$V_{out} = \frac{R_2}{R_1} (V_2 - V_1)$$

4.4 DIGITAL TO ANALOG CONVERTERS (DAC)

The DAC combines digital word ($d_1d_2d_3d_4\dots d_n$) with reference voltage (V_R) and gives analog voltage V_o . The output of DAC may current or voltage. The block diagram of DAC is shown in fig. 4.10.

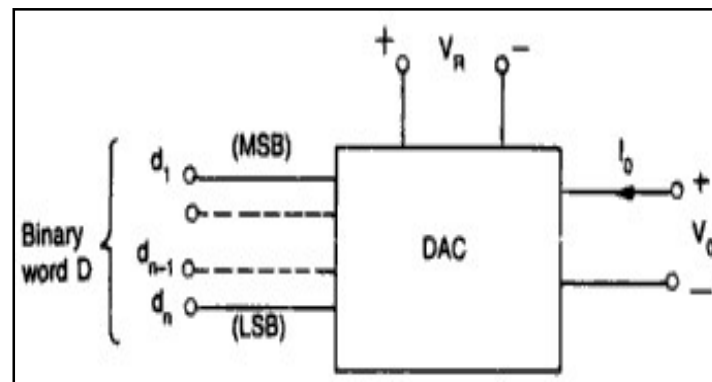

Fig. 4.10 Block diagram of DAC

For voltage output DAC, the output analog voltage is mathematically expressed as

$$V_o = K V_{FS} (d_1 2^{-1} + d_2 2^{-2} + \dots + d_n 2^{-n})$$

Where

V_o = Output voltage, V_{FS} = Full scale output voltage

K = Scaling factor adjusted to unity

d_1 = MSB with weight of $V_{FS}/2$

d_n = LSB with weight of $V_{FS}/2^n$

Types of DAC

- Binary Weighted Resistor DAC
- R-2R Ladder DAC
- Inverted R-2R Ladder DAC

4.4.1 Binary Weighted Resistor DAC

One of the simplest DAC circuits. Summing amplifier with binary weighted resistor network. It has n-electronic switches (SPDT) controlled by binary input word. The circuit diagram of Binary Weighted Resistor DAC is shown in fig. 4.11.

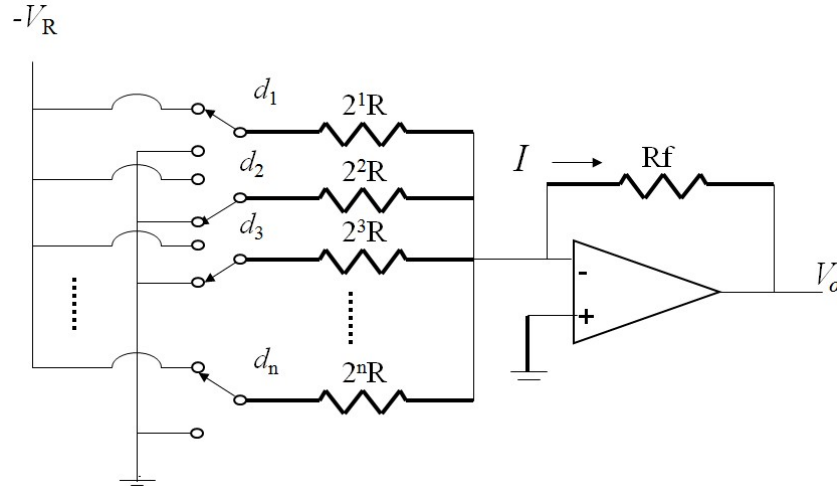

Fig. 4.11 Circuit diagram of Binary Weighted Resistor DAC

Apply KCL at node A

$$I = -(I_1 + I_2 + \dots + I_N) \quad (1)$$

$$\frac{V_O - V_A}{R_f} = - \left(\frac{-V_R - V_A}{2^1 R} (d_1) + \frac{-V_R - V_A}{2^2 R} (d_2) + \dots + \frac{-V_R - V_A}{2^N R} (d_n) \right) \quad (2)$$

Substituting $V_A = 0$, then output voltage becomes

$$V_O = V_R \frac{R_f}{R} \left(d_1 2^{-1} + d_2 2^{-2} + \dots + d_n 2^{-n} \right)$$

Advantages

- Simple Construction/Analysis
- Fast Conversion

Disadvantages

- Requires large range of resistors (2000:1 for 12-bit DAC) with necessary high precision for low resistors
- Requires low switch resistances in transistors
- Can be expensive.
- Therefore, usually limited to 8-bit resolution.

4.4.2 R-2R Ladder DAC

This DAC overcomes the drawbacks of weighted register type DAC by using R and 2R resistors. The circuit diagram of R-2R Ladder DAC is shown in fig. 4.12.

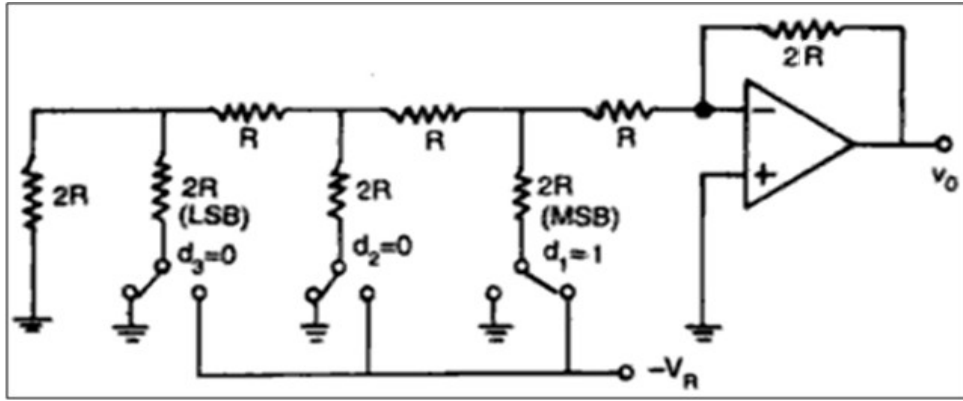
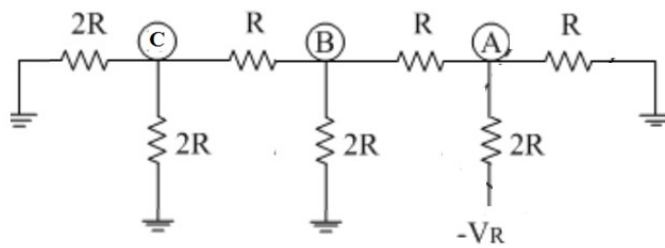

Fig. 4.12 Circuit diagram of R-2R Ladder DAC

The operation of the above ladder type DAC is explained with the binary word (d1d2d3=100)



Equivalent resistance at node C

$$\frac{2R * 2R}{2R + 2R} = R$$

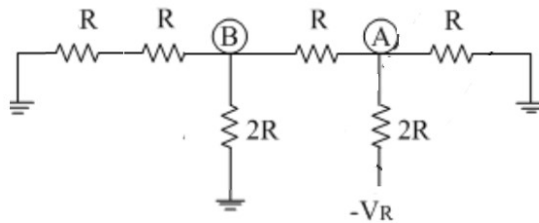

$$R + R = 2R$$

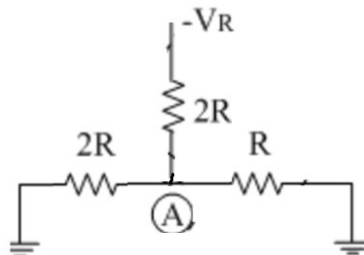
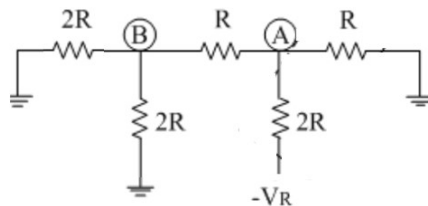

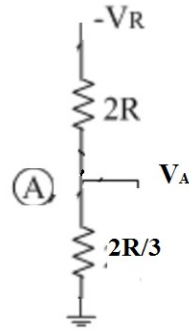

The voltage at node A, is given by potential divider method

$$V_A = \frac{\frac{2R}{3}}{2R + \frac{2R}{3}} (-V_R) = -\frac{1}{4} V_R$$

Then the output voltage for the digital input 100 is given by

$$V_{out} = -\left(\frac{2R}{R}\right) V_A$$

$$V_{out} = -\left(\frac{2R}{R}\right) \left(-\frac{1}{4} V_R\right)$$

$$V_{out} = \frac{V_R}{2}$$

Similarly for digital input 010 and 001 output voltage is given by

$$V_{out} = \frac{V_R}{4}$$

$$V_{out} = \frac{V_R}{8}$$

Similarly for digital input 111 output voltage is given by

$$V_{out} = \frac{V_R}{2} + \frac{V_R}{4} + \frac{V_R}{8}$$

Advantages

- Only two resistor values (R and 2R)
- Does not require high precision resistors

Disadvantage

- Lower conversion speed than binary weighted DAC
- Current flowing through the resistors changes as the input data changes
- More power dissipation causes heating, which in turn creates non-linearity in DAC

4.5 ANALOG TO DIGITAL CONVERTERS (ADC)

ADC has two techniques of conversion

(1) Direct type:

- Flash type
- Successive Approximation Register(SAR),
- Tracking or Servo
- Counter

(2) Indirect type:

- Charge balancing ADC
- Dual Slope

4.5.1 Flash type (parallel comparator) ADC

It consists of resistive divider network, comparators and priority encoder. For n-bit digital output, the number of comparators required is 2^n . This is fastest among all ADCs. The circuit diagram of Flash type (parallel comparator) ADC is shown in fig. 4.13.

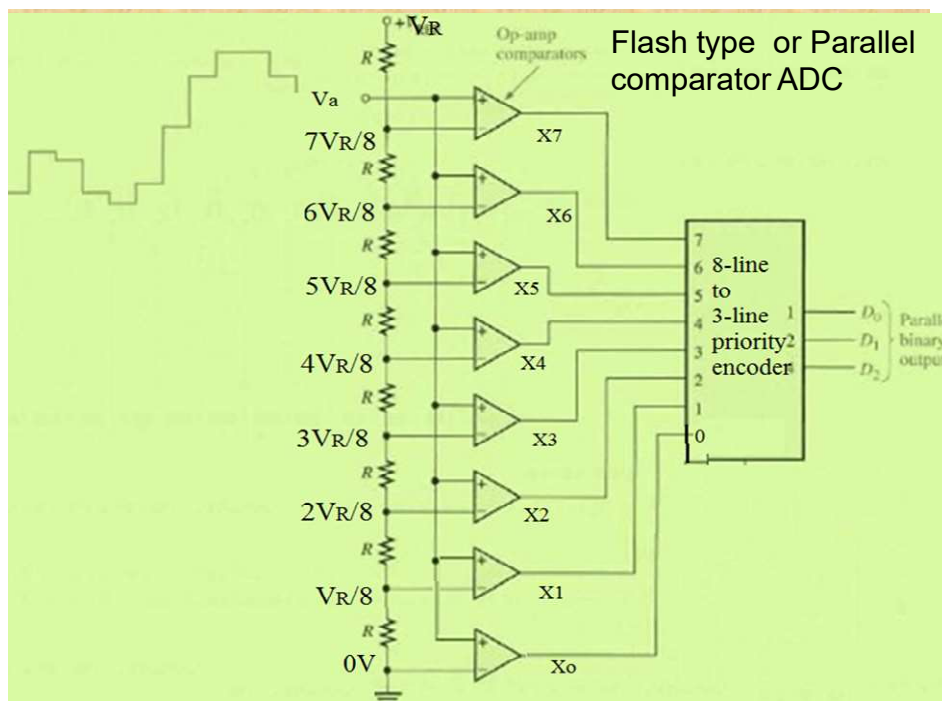

Fig. 4.13 Circuit diagram of Flash type (parallel comparator) ADC

Truth table for Flash ADC:

Va	X7	X6	X5	X4	X3	X2	X1	X0	D2	D1	D0
0 to VR/8	0	0	0	0	0	0	0	1	0	0	0
VR/8 to 2VR/8	0	0	0	0	0	0	1	1	0	0	1
2VR/8 to 3VR/8	0	0	0	0	0	1	1	1	0	1	0
3VR/8 to 4VR/8	0	0	0	0	1	1	1	1	0	1	1
4VR/8 to 5VR/8	0	0	0	1	1	1	1	1	1	0	0
5VR/8 to 6VR/8	0	0	1	1	1	1	1	1	1	0	1
6VR/8 to 7VR/8	0	1	1	1	1	1	1	1	1	1	0
7R/8 to VR/8	1	1	1	1	1	1	1	1	1	1	1

Advantages:

- It is simplest in terms of operational theory.
- Most efficient in terms of speed

Disadvantages:

- Lower resolution
- Expensive
- For each additional output the number of comparators are doubled.

4.5.2 Successive Approximation Register (SAR) ADC

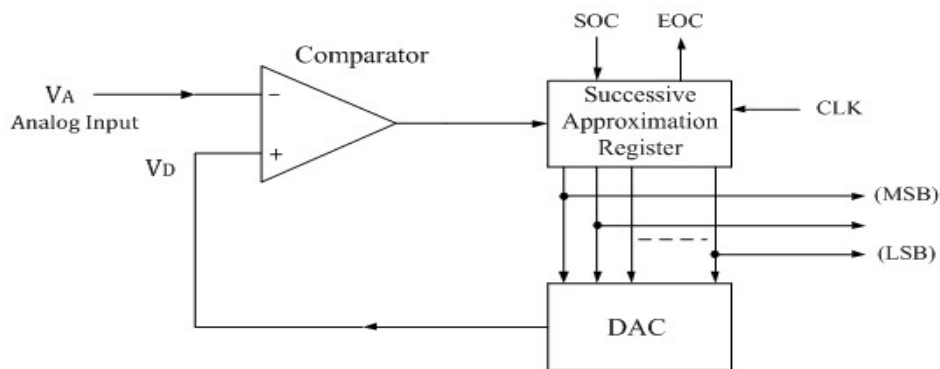

Fig. 4.14 Circuit diagram of Successive Approximation Register (SAR) ADC

It is most popularly used ADC, it works on the principle of successive approximation algorithm. Successive approximation algorithm is a simple code searching algorithm. When Start of Conversion (SOC) is given its simply generate MSB=1 remaining all bits equal to zero. If comparator output is one it sets next MSB=1 otherwise current MSB=0 next will be 1. This process is repeated until $V_A = V_D$. Once conversion is completed it generate End of Conversion (EOC) signal. This algorithm is shown below table for 8-bit output. The circuit diagram of Successive Approximation Register (SAR) ADC is shown in fig. 4.14.

Conversion process in a successive approximation ADC

Correct digital Representation	SAR output VD at different stage in Conversion	Comparator output
11010100	10000000	1
	11000000	1
	11100000	0
	11010000	1
	11011000	0
	11010100	1
	11010110	0
	11010100	0

Advantages:

- Easy fabrication of Integrated Circuits
- Less cost

Disadvantages:

- For n-bit output n number of clock cycles are required to complete the conversion process.

5.1 SPEED CONTROL DC MOTOR USING PWM

Pulse-width modulation (PWM) or duty-cycle variation methods are commonly used in speed control of DC motors. The duty cycle is defined as the percentage of digital 'high' to digital 'low' plus digital 'high' pulse-width during a PWM period.

$$Duty\ cycle = \frac{T_{ON}}{T_{ON} + T_{OFF}}$$

Fig. 1 shows the 5V pulses with 0% through 50% duty cycle.

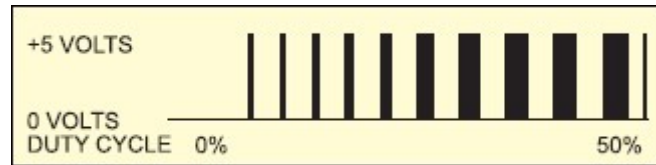

Fig..5. 1 Pluses with 0% through 50% duty cycle

$$\text{The average DC voltage of PWM signal} = V(Duty\ cycle) = V\left(\frac{T_{ON}}{T_{ON} + T_{OFF}}\right)$$

The average DC voltage value for 0% duty cycle is zero; with 25% duty cycle the average value is 1.25V (25% of 5V). With 50% duty cycle the average value is 2.5V, and if the duty cycle is 75%, the average voltage is 3.75V and so on. The maximum duty cycle can be 100%, which is equivalent to a DC waveform. Thus by varying the pulse-width, we can vary the average voltage across a DC motor and hence its speed.

The arduino mega 2560 is having 14 PWM (analog) outputs with 8-bit resolution. These pins we can generate variable analog voltages between 0V-5V by using analogWrite (pin,value). Here value is range from 0 to 255.

5.2 STEPPER MOTOR CONTROL

We can control the stepper motor using stepping modes of stepper motor. The stepping mode refers to the pattern of sequence in which stator coils are energized. There are three stepping modes for a stepper motor.

- Wave drive (One phase ON at a time)
- Full drive (Two phase ON at a time)
- Half drive (One and two phase ON at a time)

Wave drive (One phase ON at a time)

Motion	Step	W1	W2	W3	W4
Clockwise	1	1	0	0	0
	2	0	1	0	0
	3	0	0	1	0
	4	0	0	0	1
Motion	Step	W1	W2	W3	W4
Anticlockwise	1	0	0	0	1
	2	0	0	1	0
	3	0	1	0	0
	4	1	0	0	0

Full drive (Two phase ON at a time)

Motion	Step	W1	W2	W3	W4
Clockwise	1	1	1	0	0
	2	0	1	1	0
	3	0	0	1	1
	4	1	0	0	1
Motion	Step	W1	W2	W3	W4
Anticlockwise	1	1	0	0	1
	2	0	0	1	1
	3	0	1	1	0
	4	1	1	0	0

Half drive (One and two phase ON at a time)

Motion	Step	W1	W2	W3	W4
Anti Clockwise	1	1	0	0	1
	2	0	0	0	1
	3	0	0	1	1
	4	0	0	1	0
	5	0	1	1	0
	6	0	1	0	0
	7	1	1	0	0
	8	1	0	0	0
Motion	Step	W1	W2	W3	W4
Clockwise	1	1	0	0	0
	2	1	1	0	0
	3	0	1	0	0
	4	0	1	1	0
	5	0	0	1	0
	6	0	0	1	1
	7	0	0	0	1
	8	1	0	0	1

5.3 SPEED CONTROL OF A D.C. MOTOR USING SCR

In the speed control circuit of Fig.5.2., an RC network is used to control the diac voltage that triggers the gate of a thyristor. As the a.c. supply is switched ON, thyristor T remains OFF but the capacitor C is charged through motor armature and R towards the peak value of the applied a.c. voltage. The time it takes for the capacitor voltage V_C to reach the breakover voltage of the diac depends on the setting of the variable resistor T . When V_C becomes equal to the breakover voltage of diac, it conducts and a triggering pulse is applied to the thyristor gate G . Hence, T is turned ON and allows current to pass through the motor. Increasing R delays the rise of V_C and hence the breakover of diac so that thyristor is fired later in each positive half cycle of the a.c. supply. It reduces the conduction angle of the thyristor which, consequently, delivers less power to the motor. Hence, motor speed is reduced.

If R is reduced, time-constant of the RC network is decreased which allows V_C to rise to the breakover voltage of diac more quickly. Hence, it makes the thyristor fire early in each positive input half-cycle of the supply. Due to increase in the conduction angle of the thyristor, power delivered to the motor is increased with a subsequent increase in its speed. As before D is the free-wheeling diode which provides circulating current path for the energy stored in the inductance of the armature winding.

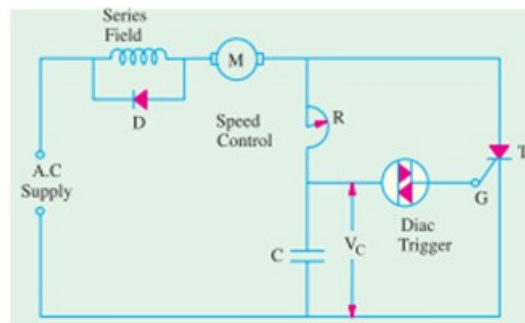

Fig. 5.2 SPEED CONTROL OF A D.C. MOTOR USING SCR